

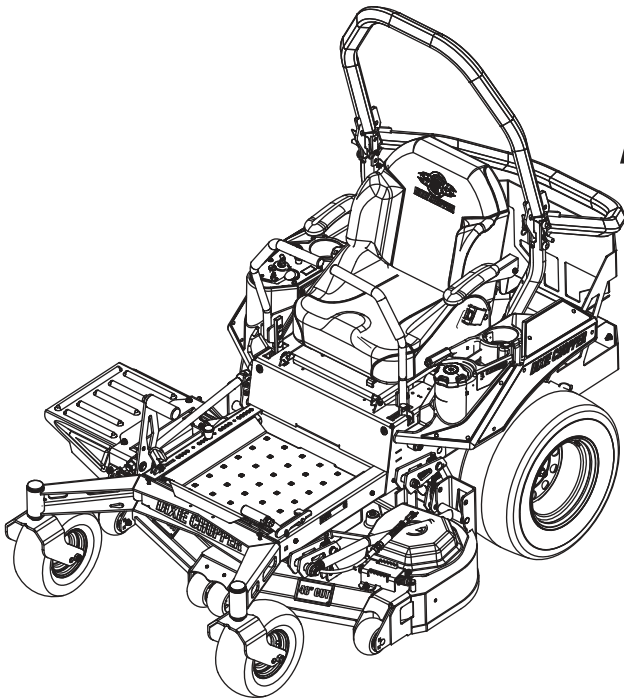

## 2018 BlackHawk Safety, Operation & Maintenance Manual



### ***BLACKHAWK***

***2248KW***

***2454KW***

***2460KW***

### ***BLACKHAWK HP***

***2248KW***

***2454KW***

***2460KW***

***2548KOE***

***2554KOE***

***2560KOE***

# 1 CONTENTS

---

## Contents

### Introduction

1.1 Important.....	2
1.2 Product Identification.....	3
1.3 Serial Numbers.....	3
1.4 Guidelines for the Disposal of Scrap Products.....	4

### Safety

2.1 How to Operate Safely.....	5
--------------------------------	---

### Specifications

3.1 Engine Specifications.....	10
3.2 Dimensions and Weights.....	12
3.3 Mower Specification.....	14
3.4 Cutting Unit Specification.....	14
3.5 Belt Specification.....	14
3.6 Recommended Lubricants.....	15
3.7 Accessories.....	16
3.8 Support Literature.....	16

### Decals

4.1 Safety Decals.....	17
4.2 Instruction Decals.....	18

### Controls

5.1 Mower Controls.....	20
5.2 BlackHawk Model Control Panel.....	21
5.3 BlackHawk HP Model Control Panel.....	23
5.4 Parking Brake.....	28
5.5 Steering Control Levers.....	28
5.6 Cutting Unit HOC Pedal.....	28
5.7 Lift Stop Pedal.....	29
5.8 Operator Controlled Discharge Chute.....	29

### Operation

6.1 Daily Inspection.....	30
6.2 Interlock System.....	31
6.3 Operating Procedure.....	33
6.4 Starting The Engine.....	34
6.5 To Stop The Engine.....	34
6.6 Driving.....	35
6.7 Height of Cut.....	36
6.8 Mowing.....	36
6.9 Mowing On Slopes.....	37
6.10 Towing The Mower.....	39

## Maintenance and Lubrication Charts

7.1 Maintenance Chart.....	40
7.2 Lubrication Chart.....	41
7.3 Fluid Requirements.....	41

## Maintenance

8.1 General Precautions.....	42
8.2 Engine.....	42
8.3 Engine Oil.....	43
8.4 Engine Air Filter.....	44
8.5 Engine Exhaust.....	45
8.6 Fuel.....	45
8.7 Tires.....	46
8.8 Wheel Mounting Procedure.....	46
8.9 Charge the battery.....	46
8.10 Battery.....	47
8.11 Drive Axle Fluid.....	48
8.12 Folding ROPS.....	49
8.13 Air Cooling System.....	50
8.14 Inspecting Blades.....	50
8.15 Sharpening Blades.....	51
8.16 Electrical System.....	51
8.17 Belts.....	52
8.18 Care and Cleaning.....	53
8.19 Mower Storage.....	54

## Adjustments

9.1 General Precautions.....	55
9.2 Forward Speed Limit Screws.....	55
9.3 Torque Specification.....	56

## Problem Solving

10.1 General.....	57
10.2 BlackHawk HP Model Fault Codes.....	58

### Proposition 65 Warning

This product contains or release chemicals known to the State of California to cause cancer and birth defects or other reproductive harm.

## 1.1 IMPORTANT

---

The Dixie Chopper BlackHawk 2248KW, 2454KW, 2460KW, 2554BR, 2560BR and the Black Hawk HP 2248KW, 2454KW, 2460KW, 2548KOE, 2554KOE, 2560KOE with a Gasoline engine is a self propelled rotary mower.

If you follow all instructions in this manual, you increase the life of your mower and keep its maximum performance. Adjustments and maintenance must always be done by an approved technician.

**IMPORTANT:** Do the maintenance included in this manual to make sure that the quality of cut is kept at a high level.

This **SAFETY, OPERATION AND MAINTENANCE MANUAL** is part of the mower and must stay with the mower always. Suppliers of both original and used mowers need to keep the documentation that comes with the mower.

You must use the mower to cut the grass and not for any other purpose. Compliance with the conditions or operation, service and repair specified by the manufacturer, are understood to be part of the correct use.

**ALL** operators **MUST** read through this manual and understand the Safety Instructions, controls, lubrication and maintenance procedures.

Make sure that you obey all safety and road traffic regulations.

You must not make any changes to the mower that the manufacturer does not approve. This type of change can release the manufacturer from the liability for any damage or injury.

When you discard worn parts, know the environmental result and use the systems available in the country where the mower is used. When the mower is at its end of life, there are guidelines in this manual for the removal of the mower from use.

Use only Dixie Chopper approved parts.

2006/42/EC

The instructions recorded here are the original instructions confirmed by Dixie Chopper, A Textron Company.

# 1 INTRODUCTION

---

## 1.2 PRODUCT IDENTIFICATION

---

### Mower Serial number plate

A Product code and Serial number



Eight digit serial number

### Location of Mower Serial number plate

The serial number plate (A) is found on the right frame rail near the front seat support.

### Engine Identification Number

The engine serial number is found on a label on the side of the engine.

### Drive Axle Identification Numbers

The drive axle serial number is found on a plate on the drive axle. There will be a separate serial number for each drive axle.

## 1.3 SERIAL NUMBERS

---

Record the mower, engine and drive axle serial numbers below:

Mower Number: \_\_\_\_\_

Engine Number: \_\_\_\_\_

Left Drive Axle: \_\_\_\_\_

Right Drive Axle: \_\_\_\_\_



## 1.4 GUIDELINES FOR THE DISPOSAL OF SCRAP PRODUCTS \_\_\_\_\_

### 1.4.1 DURING SERVICE LIFE \_\_\_\_\_

The used oil, oil filters and engine coolant are hazardous materials. Follow the recommended procedures for their safe removal.

If a fluid leaks, contain the spill to make sure that the leak does not flow into the ground or drainage system. Follow the local laws to make sure that leaks are controlled safely.

The maintenance procedures in this manual make sure that the damage that the mower can cause in the local environment is controlled safely.

Take these actions after the mower complete its full service life.

### 1.4.2 END OF SERVICE LIFE \_\_\_\_\_

Use these guidelines with applicable Health, Safety and Environmental laws. Always use the approved local waste disposal and agencies for recycled materials.

- Park the mower in a location to use all of the necessary lifting equipment.
- Use the correct tools and Personal Protective Equipment (PPE) and take instruction from the technical manuals applicable to the mower.
- Remove and keep correctly
  1. Batteries
  2. Fuel
  3. Engine coolant
  4. Oils
- Disassemble the structure of the mower and refer to the technical manuals. Give attention to parts that have mechanical pressure or tension applied to the part in the mower, including springs.
- Separate items that continue to have service life and returned to storage.
- Separate items that are worn into the material groups and removed according to the agencies for the recycled materials that are available. Common types are as shown:
  - Steel
  - Non ferrous metals
    - Aluminum
    - Brass
    - Copper
  - Plastic Materials
    - Identified
    - Can be recycled
    - Can not be recycled
    - Not Identified
  - Rubber
  - Electrical and Electronic Components
- Add items that can not be easily separated into different materials to the “General discarded materials” area.
- Do not burn the discarded materials

Change the mower records to show that the mower is not in service and is discarded. Supply this serial number to Dixie Chopper Warranty Department to close their records.

## 2 SAFETY

---

### 2.1 HOW TO OPERATE SAFELY

---

#### **WARNING**

##### **EQUIPMENT OPERATED INCORRECTLY OR WITHOUT TRAINING CAN BE DANGEROUS.**

Know the location and correct operation of controls. Operators without experience must receive instruction from another person that knows the correct operation of the equipment before you operate the mower.

Only use parts, accessories and attachments approved by Dixie Chopper.

#### 2.1.1 SAFE OPERATION

- a Read the Operator's Manual and other training material. If the operator or technician can not read this manual, the owner is responsible to describe this material to the operators and technicians.
- a Read all of the instructions for this mower carefully. Know the controls and the correct operation of the equipment.
- b Children or persons who do not understand these instructions must not use the mower. The local regulations can limit the age of the operator.
- c Never use a mower near persons, including children or animals.
- d Remember that the operator or owner is responsible for accidents or hazards that occur to other persons or their property.
- e Never carry passengers.
- f Never allow persons to operate or service the mower or its attachments without correct instructions.
- g Do not operate equipment while tired, sick or after you use alcohol or drugs.

#### 2.1.2 PREPARATION

- a When you operate the mower, wear correct clothing, slip resistant work shoes or boots, work gloves, hard hat, safety glasses and hearing protection. Long hair, loose clothing or jewelry can be caught in moving parts.
- b Do not operate the equipment with the Interlock System disconnected or the system does not operate correctly. Do not disconnect or prevent the operation of any switch.
- c Never operate equipment that is not in correct order or without decals, guards, shields, deflectors or other protective devices fastened.
- d Inspect the mower before you operate the mower. Check the tire pressure, the engine oil level, and the fuel level. Fuel is flammable. Use caution when you add the fuel to the mower.
- e Operate the mower in daylight or in good artificial light. Use caution when you operate the mower during bad weather. Never operate the mower with lightning in the area.
- f Inspect the area to select the accessories and attachments that are needed to correctly and safely do the job. Only use parts, accessories and attachments approved by Dixie Chopper.
- g Be careful of holes in the terrain and other hazards that are not visible.
- h Inspect the area where the equipment is operated. Remove all objects you can find before you operate. Be careful of obstructions above the ground (low tree limbs, electrical wires) and also underground obstacles (sprinklers, pipes, tree roots). Enter a new area carefully. Look for possible hazards.
- i Inspect the cutting system before you start the mower. Make sure the blades are free to rotate. When you rotate one blade, other blades can rotate.

#### 2.1.3 OPERATION

- a Never operate the engine without enough ventilation or in an enclosed area. The carbon monoxide in the exhaust fumes can increase to dangerous levels.
- b Never carry passengers. Keep other persons or animals away from the mower.
- c Disengage all drives and engage the parking brake before you start the engine. Only start the engine with the operator in the seat. Never start the engine with persons near the mower.
- d Keep your legs, arms and body inside the operator compartment while the mower is in operation. Keep your hands and feet away from the cutting units.
- e Do not use on the slopes greater than the safe slope limit for the equipment.
- f To guard against over turning or loss of control:

- Operate the mower up and down on the face of slopes (vertically), but not across the face (horizontally).
- Do not start or stop suddenly on slopes.
- Decrease the speed when you operate on slopes or when you must turn. Use caution when you change direction. Turf condition can change the mower stability.
- Use caution when you operate the mower near drop-offs, ditches or embankments.
- Be careful of holes in the terrain and other hazards that are not visible.
- g When you drive in the reverse direction, look behind you and down to make sure the path is clear. Do not operate the cutting unit when you drive in the reverse direction.
- h Use caution when you go near corners, trees or other objects that can prevent a clear view.
- i Equipment must meet the current regulations to be driven on the public roads.
- j Before you move across or operate on the paths or roads, turn off the PTO switch, lift the cutting unit and travel at decreased speed. Look for traffic.
- k Stop the blades when the mower is on any surface that is not grass.
- l Do not release the cut grass in the direction of persons or allow persons near the mower while in operation.
- m Do not operate the mower with damaged guards or without safety devices in position.
- n Do not change the engine governor setting or over-speed the engine. Never change or tamper with adjusters that are closed with a seal for the engine speed control.
- o Before you leave the operator compartment, for any reason:
  - Disengage all the drives and lower the cutting unit to the ground.
  - Engage the parking brake.
  - Stop the engine and remove the key.
- p When you hit an object or mower starts to cause the vibration that is not normal, inspect the mower for damage and make repairs.
- q Decrease the throttle setting before you stop the engine.
- r Do not use this equipment for uses that the mower was not made for.

## 2 SAFETY

---

### 2.1.4 ROPS

- a The ROPS is a safety device. Keep the ROPS in the vertical and locked position. Always use the seat belt when you operate the mower. Make sure the seat belt can be released quickly in an emergency.
- b Only operate the mower with the ROPS in the folded position on flat and level surfaces when necessary. Do not operate the mower with the ROPS in the folded position on slopes, near sharp edges or near water. There is no roll over protection with the ROPS in the folded position.
- c Check for clearance before you drive below objects. Do not contact tree branches, electrical wires or other objects with the ROPS.
- d Do not use the seat belt with the ROPS in the folded position.
- e Inspect the ROPS for damage. Keep the ROPS hardware fastened.
- f Do not weld, drill, change or bend the ROPS. Replace a damaged ROPS. Do not try to correct a damaged ROPS.
- g Do not remove the ROPS from the mower.
- h Dixie Chopper must approve any changes to the ROPS.

### 2.1.5 SAFE HANDLING OF FUELS

- a The fuel and the fuel vapors are flammable. Use caution when you add the fuel to the mower. The fuel vapors can cause an explosion.
- b Never use the containers that are not approved to keep or transfer fuel.
- c Never keep the mower or fuel containers near an open flame or any device that can cause the ignition of fuel or fuel vapors.
- d Never fill the fuel containers inside a vehicle or on a truck or trailer with a plastic liner. Always put the fuel container on the ground away from your vehicle before you fill the container.
- e Refuel the mower before you start the engine. When the engine is in operation or while the engine is hot, never remove the fuel cap or add fuel to the mower.
- f Refuel outdoors only and do not smoke when you add fuel. Extinguish all types of ignition.
- g The fuel nozzle must touch the rim of the fuel tank when you add fuel to the mower. Do not use a device to lock the fuel nozzle in the open position.
- h Do not over fill the fuel tank. Leave at least 1 inch (2.5 cm) below the filler neck.
- i Always tighten the fuel tank cap and container cap after you add fuel.
- j If the fuel spills on your clothing, change your clothing immediately.

### 2.1.6 MAINTENANCE AND STORAGE

- a Before you clean, adjust or repair this equipment, push PTO switch to the OFF position, lower the cutting unit to the ground, engage the parking brake, stop the engine and remove the key.
- b Make sure the mower is parked on a solid and level surface.
- c Never work on a mower that is lifted only by the jack. Always use the jack stands.
- d Never allow persons to service the mower or its attachments without correct instructions.
- e When the mower is parked, put into storage or left without an operator, lower the cutting device unless a positive mechanical lock is used.
- f When you put the mower on a trailer or put the mower in storage, close the fuel valve. Do not keep fuel near flames or drain the fuel inside a building.
- g Disconnect the battery before you service the mower. Always disconnect the negative battery cable before the positive battery cable. Always connect the positive battery cable before the negative battery cable.
- h Charge the battery in an area with good airflow. The battery can release hydrogen gas that is explosive. To prevent an explosion, keep any device that can cause sparks or flames away from the battery.
- i Disconnect the battery charger from the power supply before you connect or disconnect the battery charger to the battery. Wear protective clothing and use insulated tools when you service the battery.
- j Be careful and wear gloves when you check or service the cutting unit blades. Replace any damaged blades, do not try to correct a damaged blade.
- k Keep your hands and feet away from parts that move. Do not adjust the mower with the engine in operation, unless the adjustment needs the engine in operation.
- l Carefully release the pressure from components with stored energy.

- m To prevent injury from the hot, high pressure oil, never use your hands to check for oil leaks. Use the paper or cardboard to find leaks.
- n The drive axle fluid pressure can have enough force to enter your skin. If drive axle fluid has entered your skin, a doctor must remove the drive axle fluid surgically within a few hours or gangrene can occur.
- o Make sure the drive axle system is in good condition before you start the engine.
- p Keep the mower and the engine clean.
- q Allow the engine to become cool before storage and always remove the ignition key.
- r Keep all nuts, bolts and screws tight to make sure the equipment is in safe condition.
- s Replace worn or damaged parts for safety. Replace damaged or worn decals. Only use parts, accessories and attachments approved by Dixie Chopper.
- t To decrease the fire hazard, remove materials that burn from the engine, muffler, battery tray and fuel tank area.
- u Disconnect the battery and controller connectors before you weld on this mower.

### 2.1.7 WHEN YOU PUT THE MOWER ON A TRAILER

- a Be careful when you load or unload the mower on a trailer. Trailer must be wider than the mower and can carry the weight of the mower.
- b Use a full-width ramp to load or unload the mower on a trailer.
- c Use straps, chains, cables or ropes to fasten the mower to the trailer. Both front and rear straps must be sent down and toward sides of trailer.
- d Make sure that all latches are correctly fastened.

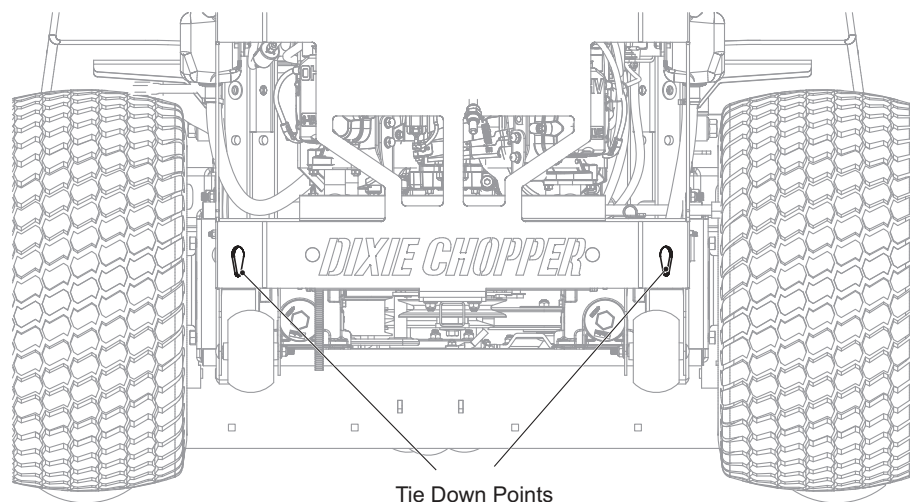
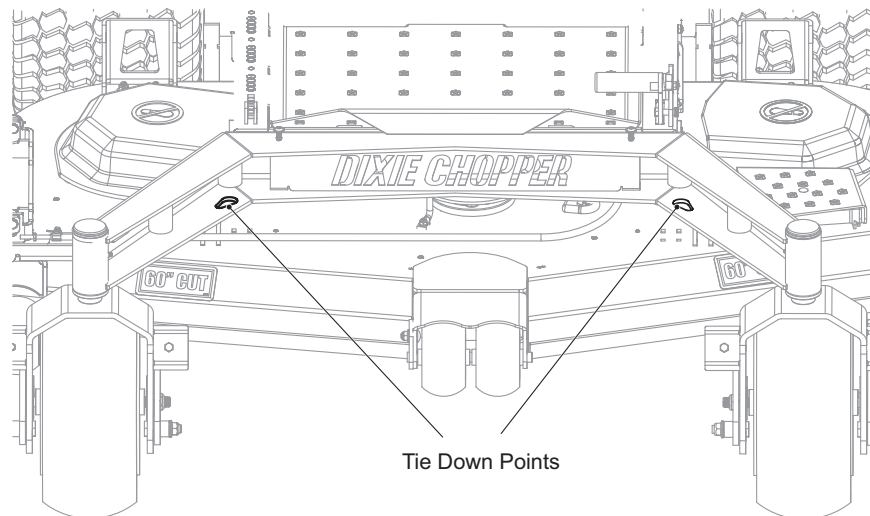

## 2 SAFETY

---

### 2.1.8 IMPORTANT SAFETY NOTES

---



*This safety alert symbol gives a warning of possible hazards.*

**DANGER** - Indicates a dangerous condition that WILL cause death or injury unless it is prevented.

**WARNING** - Indicates a dangerous condition that CAN cause death or injury unless it is prevented.

**CAUTION** - Indicates a dangerous condition that can cause injury and property damage unless it is prevented. The label can indicate work procedures that are not safe.

**NOTICE** - Indicates a condition that can cause damage to the property unless it is prevented. The label can indicate work procedures that are not safe.

*Some illustrations in this manual show the shields, guards or plates, removed. Do not operate this equipment without these devices correctly fastened in position.*



#### **WARNING**

The Interlock System on this mower prevents the operation of the mower unless a.) The parking brake is engaged. b.) The PTO switch is in the OFF position and c.) The steering control levers are in the Neutral position. The system will stop the engine if the operator leaves the operator position without:

- a.) The parking brake engaged
- b.) The steering control levers in the Neutral position and
- b.) the PTO switch in the OFF position.

NEVER operate the mower unless the Interlock System operates correctly.



#### **WARNING**

1. Before you leave the operator position, for any reason:
  - a. Return the steering control levers to Neutral.
  - b. Disengage all drives.
  - c. Lower the cutting unit to the ground.
  - d. Engage the parking brake.
  - e. Stop the engine and remove the ignition key.
2. Keep your hands, feet and clothing away from moving parts. Wait for all movement to stop before you clean, adjust or service the mower.
3. Keep persons and animals away from the area of operation.
4. Never carry passengers.
5. Never operate the equipment without a correctly fastened grass deflector in position.

If additional information or service is needed, contact your Authorized Dixie Chopper Dealer. Your Dealer knows the current methods to service this equipment.

**3.1 ENGINE SPECIFICATIONS**

	<b>BlackHawk Models</b>	<b>BlackHawk HP Models</b>
Make	Kawasaki	Kawasaki
Model	<b>2248KW:</b> FS651V <b>2454KW / 2760KW:</b> FS730V	<b>2248KW:</b> FX691V <b>2454KW / 2460KW:</b> FX730V
Type	Four cycle, air cooled, V-Twin, OHV	Four cycle, air cooled, V-Twin, OHV
Number of Cylinders	2	2
Bore and Stroke	3.07 in. (7.8 cm) x 2.99 in. (7.6 cm)	3.07 in. (7.8 cm) x 2.99 in. (7.6 cm)
Total Displacement	44.3 in <sup>3</sup> (0.726 l)	44.3 in <sup>3</sup> (0.726 l)
Intake System	Naturally Aspirated	Naturally Aspirated
Gross Intermittent Power	<b>FS651V:</b> 22 hp (16.4 kW) @ 3600 RPM <b>FS730V:</b> 24 hp (17.9 kW) @ 3600 RPM	<b>FX691V:</b> 22 hp (16.4 kW) @ 3600 RPM <b>FX730V:</b> 23.5 hp (17.6 kW) @ 3600 RPM
Compression Ratio	8.2:1	8.2:1
Maximum Speed	3650 ± 100 rpm (No Load)	3650 ± 100 rpm (No Load)
Low Idle	1550 ± 100 rpm (No Load)	1550 ± 100 rpm (No Load)
Rotation	Clockwise viewed at flywheel	Clockwise viewed at flywheel
Fuel System	2 Barrel Float Feed Carburetor	2 Barrel Float Feed Carburetor
Fuel	87 Octane Gasoline Maximum 10% Ethanol	87 Octane Gasoline Maximum 10% Ethanol
Ignition System	Two magnetos triggered by flywheel magnets	Two magnetos triggered by flywheel magnets
Spark Plug	NGK BPR4ES (Dixie P/N 902453)	NGK BPR4ES (Dixie P/N 902453)
Spark Plug Gap	0.030 Inch (0.76 mm)	0.030 Inch (0.76 mm)
Engine Oil (API Class)	SF, SG, SH, SJ or SL	SF, SG, SH, SJ or SL
Oil Pan Capacity	2.2 quarts (2.1 l)	2.2 quarts (2.1 l)
Starter	12 Volt Electric Solenoid Shift Starter	12 Volt Electric Solenoid Shift Starter
Alternator	12 Volt, 20 Amp	12 Volt, 20 Amp
Dry Weight	90 lb. (40.8 kg)	101 lb. (45.8 kg)
Dimensions (Length x Width x Height)	19.6 x 17.99 x 15.08 in. (49.8 x 45.7 x 38.3 cm)	18.9 x 18.2 x 22.2 in. (47.9 x 46.2 x 56.5 cm)
Emission Regulation		

### 3 SPECIFICATIONS

---

	<b>2548KOE/2554KOE/2560KOE</b>
Make	Kohler
Model	EZT740
Type	Four cycle, air cooled, V-Twin, OHV
Number of Cylinders	2
Bore and Stroke	3.27 x 2.7 in. (8.3 x 6.9 cm)
Total Displacement	45.6 in <sup>3</sup> (0.747 l)
Intake System	Naturally Aspirated
Gross Intermittent Power	25 hp (18.6 kW) @ 3600 RPM
Compression Ratio	9.0:1
Maximum Speed	3600 ± 100 rpm (No Load)
Low Idle	1750 ± 100 rpm (No Load)
Rotation	Clockwise viewed at flywheel
Fuel System	Closed Loop Electronic Fuel Injection (EFI)
Fuel	87 Octane Gasoline Maximum 10% Ethanol
Ignition System	Two magnetos triggered by flywheel magnets
Spark Plug	Champion RC12YC
Spark Plug Gap	0.030 Inch (0.76 mm)
Engine Oil (API Class)	SJ or higher
Oil Pan Capacity	2.0 quarts (1.9 l)
Starter	12 Volt Electric Solenoid Shift Starter
Alternator	12 Volt, 20 Amp
Dry Weight	91 lb. (41.3 kg)
Dimensions (Length x Width x Height)	18.8 x 18.9 x 17 in. (47.8 x 48 x 43.2 cm)
Emission Regulation	



**3.2 DIMENSIONS AND WEIGHTS**

	<b>2248KW / 2548KOE</b>	<b>2454KW/2554KOE/2554BR</b>	<b>2460KW/2560KOE/2560BR</b>
A - Width of Cut	48 inch (121.9 cm)	54 inch (137.2 cm)	60 inch (152.4 cm)
B - Maximum Width	63.6 inch (161.5 cm)	69.6 inch (176.8 cm)	76 inch (193.04 cm)
C - Height (ROPS Up)	71 inch (180.3 cm)		
D - Height (ROPS Folded)	50 inch (127 cm)		
E - Total length (ROPS Up)	81.8 inch (207.7 cm)		
F - Total length (ROPS Folded)	85.8 inch (217.9 cm)		
G - Wheel Base	49.2 inch (124.8 cm)		
H - Front Wheel Track	35.4 inch (89.9 cm)		
J - Rear Wheel Track	38.3 inch (97.3 cm)		
Weight of unit	Kawasaki BlackHawk - 1104 lb. (500.8 kg) BlackHawk HP - 1116 lb. (506.2 kg)  Kohler BlackHawk HP - 1121lb. (508.5 kg)	Kawasaki BlackHawk - 1114 lb. (505.3 kg) BlackHawk HP - 1132 lb. (513.5 kg)  Kohler BlackHawk HP - 1138 lb. (516.1 kg)	Kawasaki BlackHawk - 1121 lb. (508.5 kg) BlackHawk HP - 1140 lb. (517.1 kg)  Kohler BlackHawk HP - 1144 lb. (518.9 kg)

<b>Tire Specifications</b>					
Front Wheel			Rear Wheel		
Tire Size	Type	Tire Pressure	Tire Size	Type	Tire Pressure
13 x 6.5-6		12-15 psi (0.83-1.03 BAR)	23 x 10.5-12	Turf	8-10 psi (0.55-0.69 BAR)

### 3 SPECIFICATIONS

---

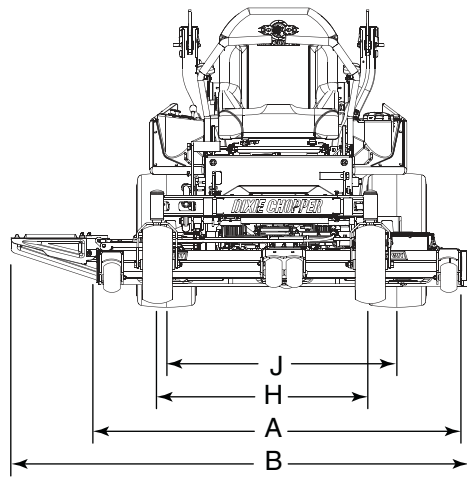
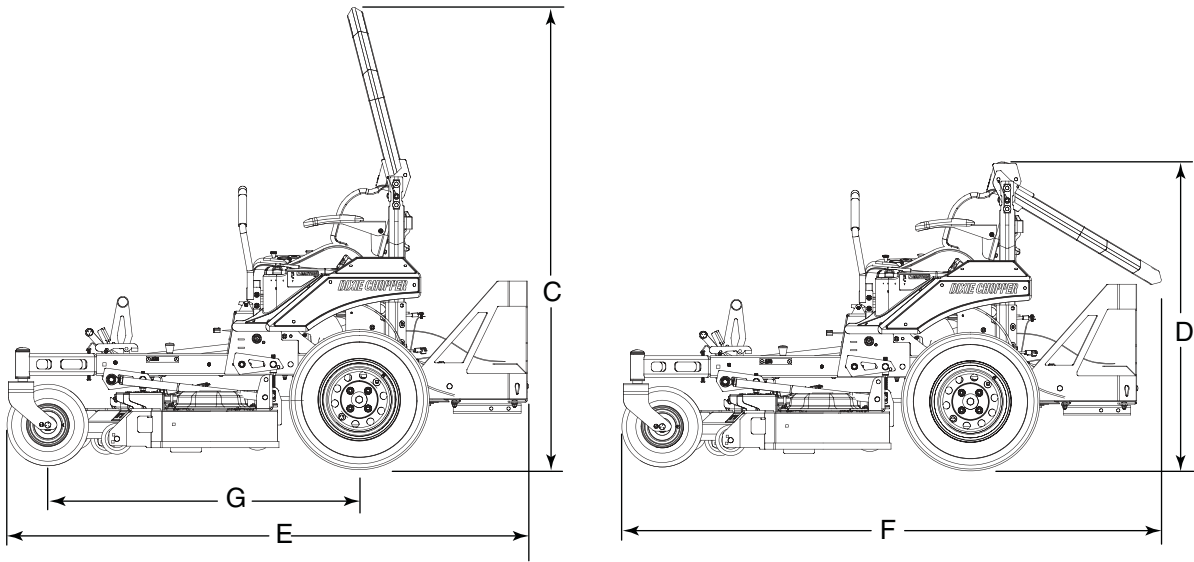

**3.3 MOWER SPECIFICATION**

Battery: 12V, 350 CCA

Service Brake: Dynamic braking through the traction circuit

Parking Brake: Hand lever connected to drum brakes on wheel motor

Fuel Tank: One 6.8 U.S. Gallons (25.7 l) tank

Steering: Hand lever speed and direction controls for left and right rear wheel

Traction Drive: Belt driven dual hydrostatic drive axles  
 BlackHawk Models: 10 cc pump with 260 cc motor  
 BlackHawk HP Models: 12 cc pump with 260 cc motor

Cutting Unit Drive: Belt drive with electric clutch

Ground Speed:  
 BlackHawk Models 0-9 mph (0-14.5 kph)  
 BlackHawk HP Models 0-10 mph (0.16.1 kph)

Reverse Speed:  
 BlackHawk Models 0-9 mph (0-14.5 kph)  
 BlackHawk HP Models 0-10 mph (0.16.1 kph)

2248KW / 2548KOE Cutting Performance: Up to 3.8 acres/hr. (1.54 hectares/hr) @8 mph (12.87 km/hr)  
 2454KW / 2554KOE / 2554BR Cutting Performance: Up to 4.3 acres/hr. (1.74 hectares/hr) @8 mph (12.87 km/hr)  
 2760KW / 2760 EFI Cutting Performance: Up to 4.8 acres/hr. (1.94 hectares/hr) @8 mph (12.87 km/hr)

**3.4 CUTTING UNIT SPECIFICATION**

	<b>2248KW / 2548KOE</b>	<b>2454KW/2554KOE/2554BR</b>	<b>2460KW/2560KOE/2560BR</b>
Blade Length	17.25 inch (43.8 cm)	19 inch (48.2 cm)	20-1/2 inch (54.3 cm)
Number of blades	3		
Height of cut	1 to 5 in. (2.5 to 12.7 cm) in 1/4 in. (0.6 cm) increments		
Height of cut adjustment	A foot lever to lift or lower the cutting unit with a HOC stop installed in different slots for specified HOC.		
Blade Tip Speed @ 3600 rpm engine speed	18,398 feet/minute (5,908 meters/minute)	18,257 feet/minute (5,565 meters/minute)	18,451 feet/minute (5,624 meters/minute)

**3.5 BELT SPECIFICATION**

Traction Belt Part Number **4354028**, A-Section, Raw, 66.48 in. EL Belt

48 in. Deck Belt Part Number **4353467**, B-Section, Wrapped, 152 in. EL Belt

54 in. Deck Belt Part Number **4353468**, B-Section, Wrapped, 163.2 in. EL Belt

60 in. Deck Belt Part Number **4350706**, B-Section, Wrapped, 173 in. EL Belt

### 3 SPECIFICATIONS

---

#### 3.6 RECOMMENDED LUBRICANTS

---

Engine Oil:

Kawasaki FS651V and FS730V: API Classification grades SF, SG, SH, SJ or SL

Temperature	Viscosity
Above 95° F (35° C)	SAE 40
68° to 95° F (20° to 35° C)	SAE 30 or SAE 10W-30 or SAE 10W-40 or SAE 40
32° to 68° F (0° to 20° C)	SAE 30 or SAE 10W-30 or SAE 10W-40
-4° to 32° F (-20° to 0° C)	SAE 5W-20 or SAE 10W-30 or SAE 10W-20
Below -4° F (-20° C)	SAE 5W-20

Kawasaki FX691V and FX730V: API Classification grades SF, SG, SH, SJ or SL

Temperature	Viscosity
Above 95° F (35° C)	SAE 40 or SAE20W-50 or SAE 10W-40
68° to 95° F (20° to 35° C)	SAE 40 or SAE 30 or SAE 20W-50 or SAE 10W-40 or SAE 10W-30
50° to 68° F (10° to 20° C)	SAE 30 or SAE 20W-50 or SAE 10W-40 or SAE 10W-30
32° to 50° F (0° to 10° C)	SAE 20W-50 or SAE 10W-40 or SAE 10W-30
14° to 32° F (-10° to 0° C)	SAE 10W-40 or SAE 10W-30 or SAE 5W-20
Below 14° F (-10° C)	SAE 5W-20

Kohler Engine: API Classification grades SJ or higher

Temperature	Viscosity
Above 50° F (10° C)	SAE 30 or SAE 10W-30
32° to 50° (0° to 10° C)	SAE 10W-30
0° to 32° F (-18° to 0° C)	SAE 5W-30 or SAE 10W-30
Below 0° F (-18° C)	SAE 5W-30

Drive Axle Fluid:

The standard drive axle fluid is Parker HT-1000 oil.

Grease:

Texaco Starplex 2EP Moly (NLGI Grade 2-EP Lithium Complex Grease containing Molybdenum Disulfide) or equivalent.

## 3.7 ACCESSORIES

---

### 3.7.1 STRIPING KIT

---

Kit Number 902985

### 3.7.2 ELECTRIC DECK LIFT

---

Kit Number 4366006

### 3.7.3 REPLACEMENT BLADES

---

Standard 17.25 inch (43.8 cm) X-Blade Part Number 30227-50X (For 48 inch (121.9 cm) cutting unit)  
Standard 19 inch (48.2 cm) X-Blade Part Number 301245 (For 54 inch (137.2 cm) cutting unit)  
Standard 20-1/2 inch (54.3 cm) X-Blade Part Number 30227-60X (For 60 inch (152 cm) cutting unit)  
Optional 17.25 inch (43.8 cm) Twist Blade Part Number 30227-50T (For 48 inch (121.9 cm) cutting unit)  
Optional 17.25 inch (43.8 cm) Eliminator Blade Part Number 30227-50E (For 48 inch (121.9 cm) cutting unit)  
Optional 19 inch (48.2 cm) Twist Blade Part Number 301245T (For 54 inch (137.2 cm) cutting unit)  
Optional 19 inch (48.2 cm) Eliminator Blade Part Number 301245E (For 54 inch (137.2 cm) cutting unit)  
Optional 20-1/2 inch (54.3 cm) Twist Blade Part Number 30227-60T (For 60 inch (152 cm) cutting unit)  
Optional 20-1/2 inch (54.3 cm) Eliminator Blade Part Number 30227-60E (For 60 inch (152 cm) cutting unit)

### 3.7.4 MULCHER KITS

---

48 inch Mulcher Kit Number 4385107  
54 inch Mulcher Kit Number 4385108  
60 inch Mulcher Kit Number 670869

### 3.7.5 DISCHARGE ENHANCEMENT KITS

48 inch Discharge Enhancement Kit Number 903467  
54 inch Discharge Enhancement Kit Number 903473  
60 inch Discharge Enhancement Kit Number 670870

### 3.7.6 SPRINGER FORKS

---

Kit Number 4369086

### 3.7.7 HITCH

---

Kit Number 4369190

### 3.7.8 LIGHT KIT

---

Kit Number 4382367

### 3.7.9 SUSPENSION SEAT

---

Kit Number 4368966

### 3.7.10 TRASH BUCKET

---

Kit Number 4382750

## 3.8 SUPPORT LITERATURE

---

Contact your Dixie Chopper Dealer for a complete listing of literature available for your mower.

Mower Parts Manual: 4420785

## 4 DECALS

### 4.1 SAFETY DECALS

Understand the purpose of these decals. The decals are important to the safe operation of the mower. REPLACE THE DAMAGED DECALS IMMEDIATELY.



Serious injury or death can result from blade contact or from contacting the belts or pulleys with the engine running. Deck spindles may have a fan installed above or below the pulleys.

Do not operate the mower with the discharge chute or belt guards removed. Make sure the Interlock System operates correctly.



Read the manual before you operate the mower

Pick up sticks, stones and other debris that can be thrown by the mower.

Wear eye protection when you operate the mower.

Wear ear protection when you operate the mower.

Keep bystanders away from the mower.

Be careful of debris thrown by the mower.

Use caution when you operate on slopes. Only operate on slopes with the ROPS in the vertical position.

Do not carry passengers.

4.2 INSTRUCTION DECALS

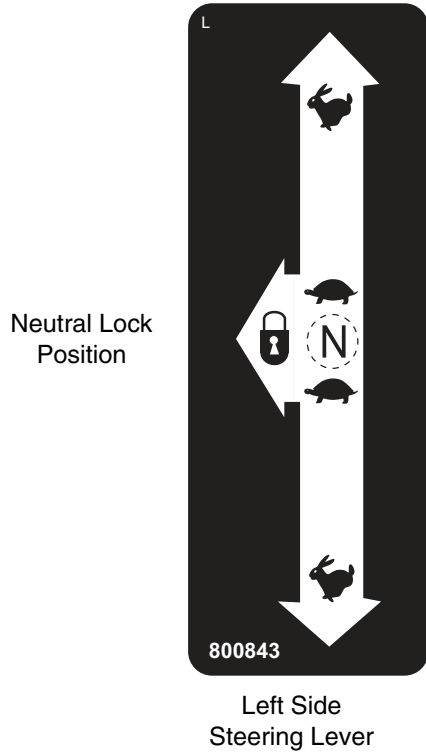

Fast Forward

Slow Forward  
Neutral

Slow Reverse

Fast Reverse

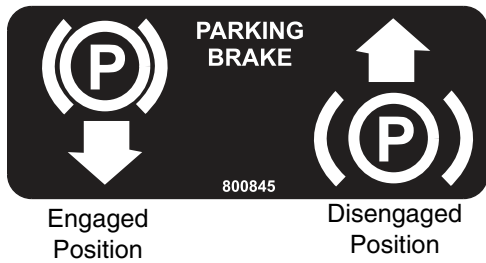
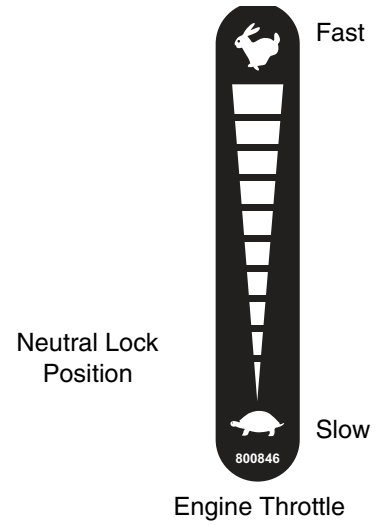

4 DECALS

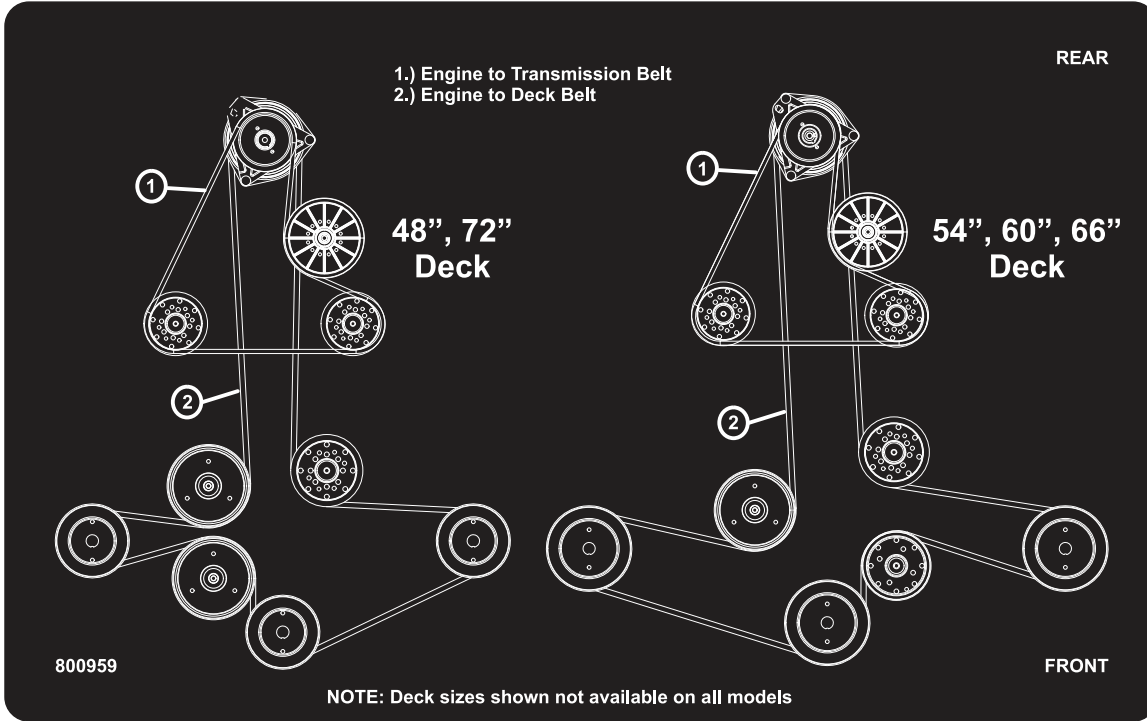

- 4 <sup>3</sup>/<sub>4</sub>
- 3 <sup>3</sup>/<sub>4</sub>
- 2 <sup>3</sup>/<sub>4</sub>
- 1 <sup>3</sup>/<sub>4</sub>
  
- 4 <sup>1</sup>/<sub>2</sub>
- 3 <sup>1</sup>/<sub>2</sub>
- 2 <sup>1</sup>/<sub>2</sub>
- 1 <sup>1</sup>/<sub>2</sub>
  
- 4 <sup>1</sup>/<sub>4</sub>
- 3 <sup>1</sup>/<sub>4</sub>
- 2 <sup>1</sup>/<sub>4</sub>
- 1 <sup>1</sup>/<sub>4</sub>
  
- 5
- 4
- 3
- 2
- 1

800975





5.1 MOWER CONTROLS

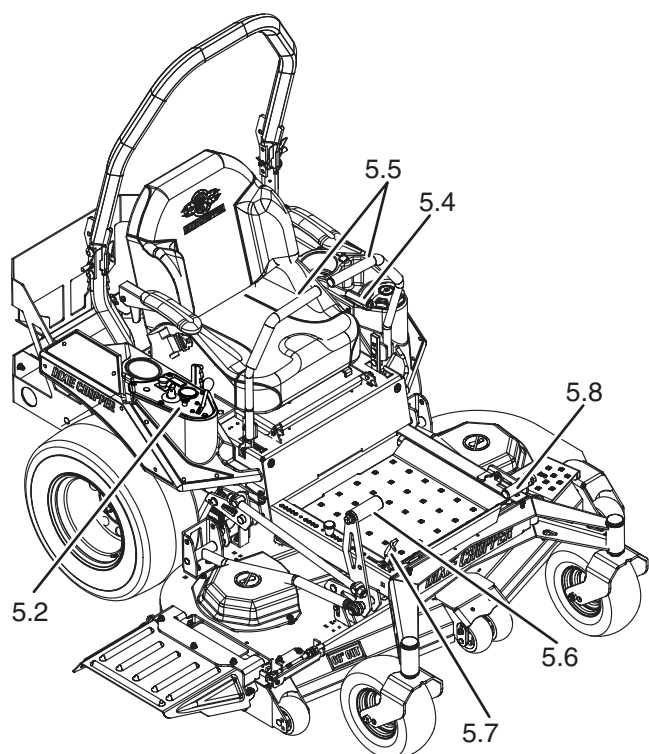

BlackHawk Models

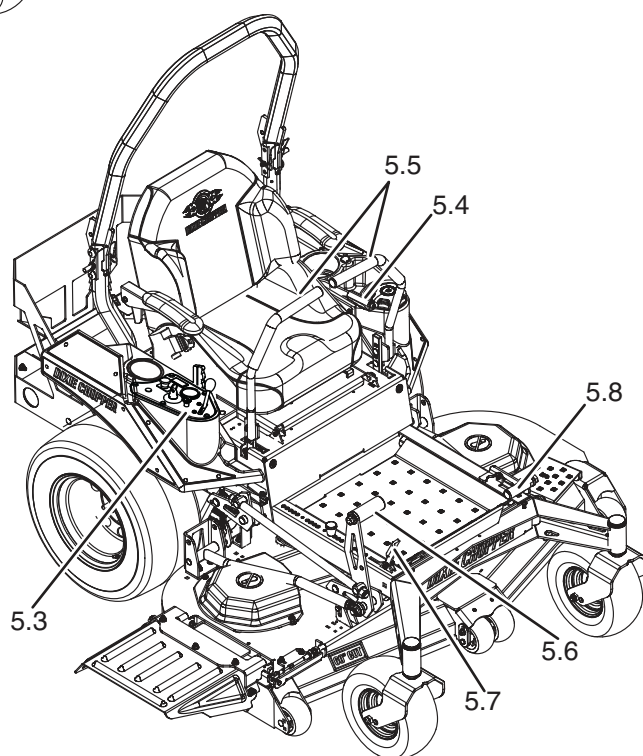

BlackHawk HP Models

# 5 CONTROLS

## 5.2 BLACKHAWK MODEL CONTROL PANEL

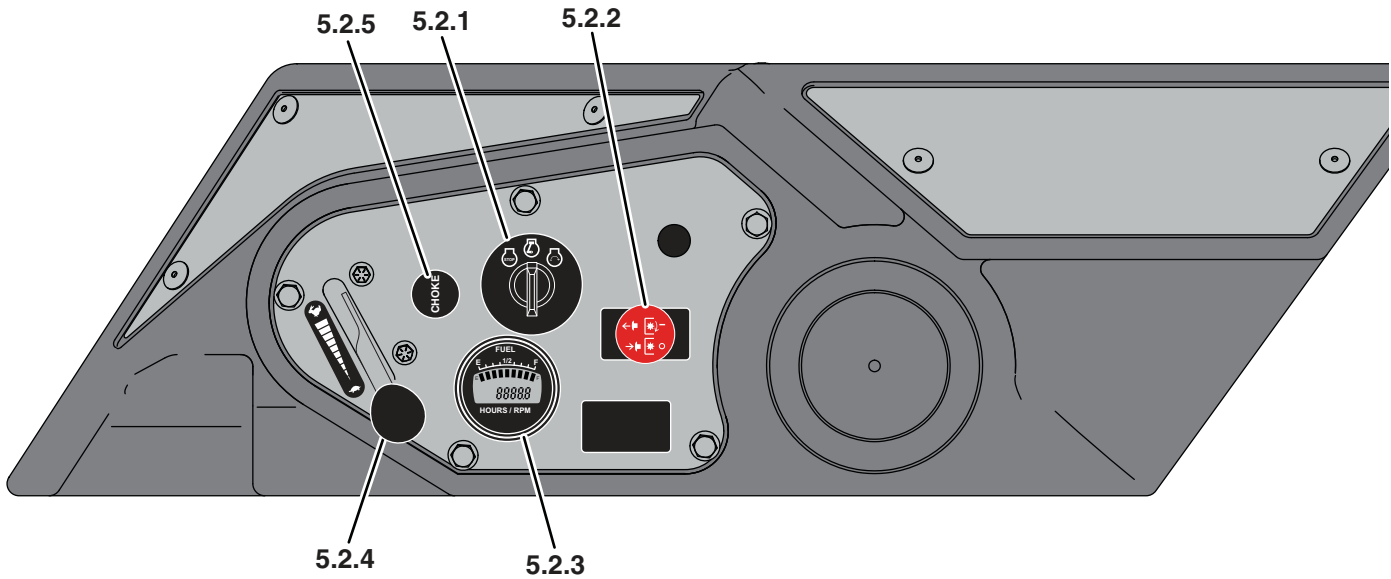

### 5.2.1 IGNITION SWITCH

The ignition switch has three positions, OFF, RUN and START.

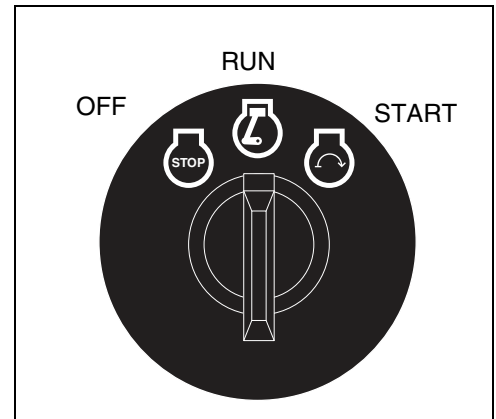

### 5.2.2 PTO SWITCH

The PTO switch is a 2-position knob type switch to engage and to disengage the cutting unit. The PTO switch must be in the OFF (down) position to start the engine.

Pull on the red knob to move the switch to the ON position. When the PTO switch is in the ON position, the cutting unit is engaged.

Always mow with the throttle lever in the fast position.

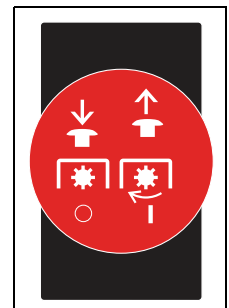

## 5.2.3 COMBINATION GAUGE

The combination gauge shows the hours of operation, fuel level and engine speed.

The hour meter and engine speed is displayed in the center of the gauge. The hours of operation is shown when the ignition switch is in the RUN position and the engine is not started. Once the engine starts, the engine speed is shown on the gauge.

The fuel gauge is above the hour meter/engine speed in the center of the gauge. The fuel gauge shows the level of fuel in the tank. Do not allow the tank to become empty while you operate the mower.

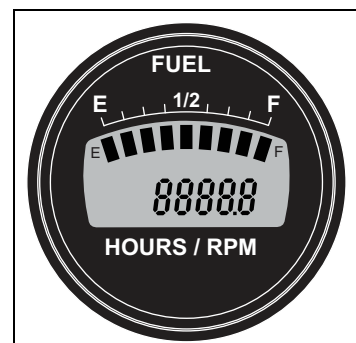

## 5.2.4 THROTTLE LEVER

The throttle lever controls the engine speed. Always operate the mower at full throttle during normal operation.

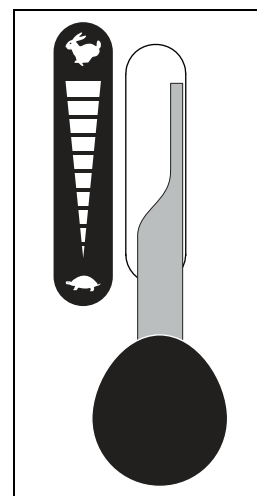

## 5.2.5 CHOKE CONTROL

When you start a cold engine, pull the choke control to the choke position. Slowly push the choke lever to the RUN position when the engine becomes warm.

### NOTICE

The choke control is not necessary to start a warm engine.

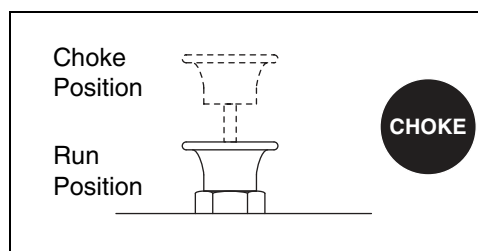

## 5 CONTROLS

### 5.3 BLACKHAWK HP MODEL CONTROL PANEL

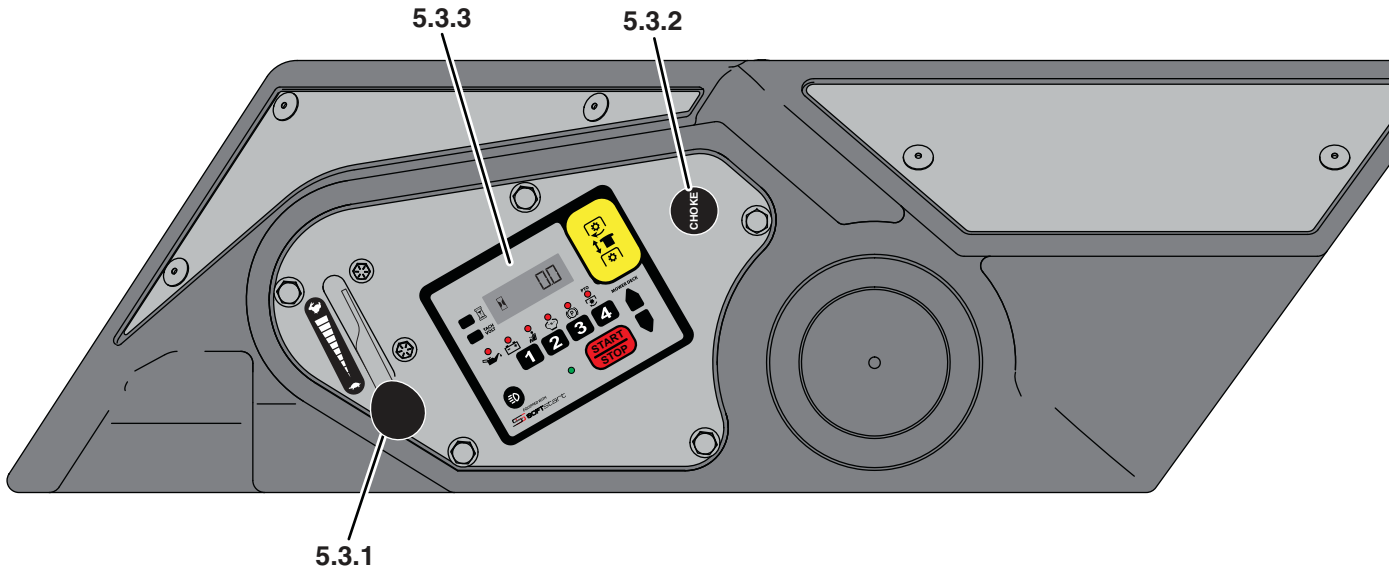

#### 5.3.1 THROTTLE LEVER

The throttle lever controls the engine speed. Always operate the mower at full throttle during normal operation.

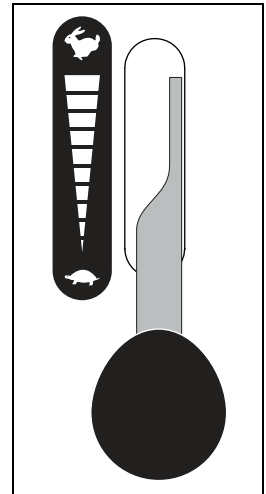

#### 5.3.2 CHOKE CONTROL

**Kawasaki engines only:** When you start a cold engine, pull the choke control to the choke position. Slowly push the choke lever to the RUN position when the engine becomes warm.

### NOTICE

The choke control is not necessary to start a warm engine.

Choke  
Position

Run  
Position



CHOKE

### 5.3.3 DISPLAY PANEL

The display panel controls the operation of the mower.

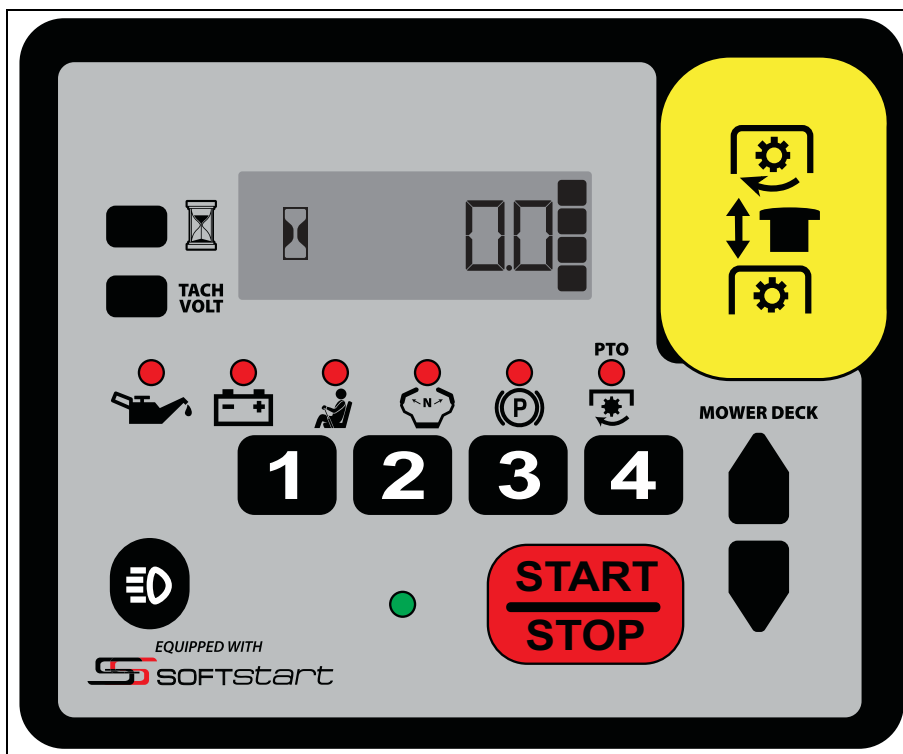

#### 5.3.3.1 Start-Up

A start-up code must be entered before the mower can be operated. Use the four number buttons to enter the start-up code. The default start-up code is **1234**. When the correct code is entered, the hours of operation will be displayed and panel lights will turn on.

**NOTE:** The start-up code can be changed from the default code by the owner. If the start-up code is longer than five numbers, only the last five numbers pressed will be shown on the display. See **5.3.3.10**

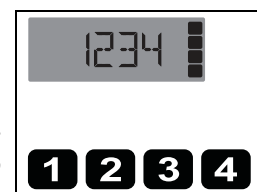

If the incorrect code is entered, **WRONG CODE** will flash on the display. The correct code must be entered before the mower can be operated.

If the operator is not in the seat, the system will shut down 15 seconds after the start-up code is entered. If the operator is in the seat, the system will shut down in 15 minutes unless the engine is started.

#### 5.3.3.2 Fuel Gauge

The fuel gauge is shown on the right hand side of the LCD display in a four bar graph with each bar equal to 1/4 tank. When all four bars are shown, the fuel tank is full. When no bars are shown, the fuel tank is empty. Do not allow the tank to become empty while you operate the mower.

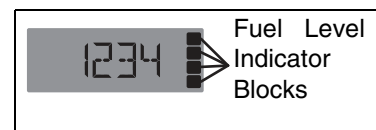

## 5 CONTROLS

### 5.3.3.3 Warning Lights

Six red lights alert the operator of the mower status.



**Engine Oil** - The red engine oil pressure light indicates low engine oil pressure. Shut down the mower immediately. Inspect the oil level in the engine. If the oil light remains on with the oil at proper level, shut off the engine and tow or trailer the mower back to a service area. NEVER operate the engine with the oil light on, severe damage to the engine can occur.



**Battery Voltage** - The battery voltage light indicates the system voltage is below 12 VDC or above 15 VDC. Have the battery charging system checked.



**Operator Presence** - The operator in seat light indicates the seat switch is in the open position. The operator must be in the seat to start the engine. The engine will stop if the operator leaves the seat with the PTO switch ON, parking brake disengaged or the steering levers out of the neutral position.



**Neutral Position** - The neutral position light indicates the steering levers are not in the neutral position.



**Parking Brake** - The parking brake light indicates the parking brake is disengaged.



**PTO Switch** - The PTO switch light indicates the PTO switch is in the ON position.

### 5.3.3.4 Display Modes

During normal operation, the display panel can show the engine hour meter, service timer, blade run time, the engine speed and the system voltage on the LCD display. Alarms and error codes will override the display modes.

To display the engine hour meter, service timer or blade run time, press the hour meter button on the left side of the display. Press the hour meter button again to cycle between the screens.

To reset the service timer, press and release the hour meter button until the service timer screen is on the display. Press and hold the hour meter button until the counter resets. The blade run time and engine hour meter cannot be reset.

To display the engine speed or the system voltage, press the TACH/VOLT button on the left side of the display. Press the button again to cycle between engine speed and system voltage.

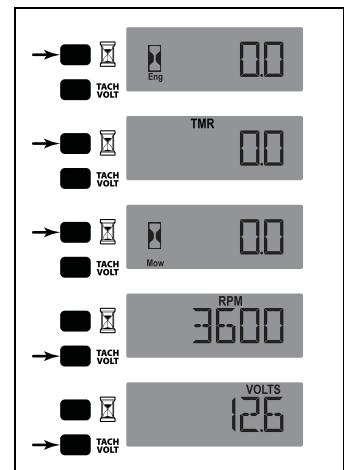

### 5.3.3.5 PTO Switch

The PTO switch is a 2-position knob type switch to engage and to disengage the cutting unit. The PTO switch must be in the OFF (down) position to start the engine.

Pull on the yellow knob to move the switch to the ON position. When the PTO switch is in the ON position, the cutting unit is engaged and the PTO switch light is on.

Always mow with the throttle lever in the fast position.

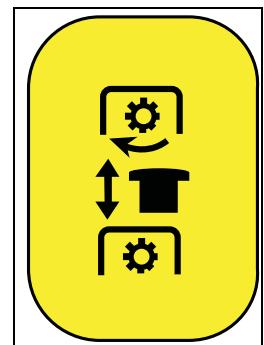

## 5.3.3.6 Headlight Button

Press and release the headlight button to turn on the lights. Press the button again to turn off the lights.

**NOTE:** *The headlights are an optional accessory. The button does not function unless the light accessory is installed.*

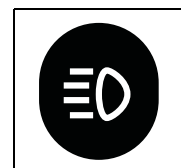

## 5.3.3.7 START/STOP Button

The START/STOP button is used to start or stop the engine. The engine can only be started when the start engine light to the left of the START/STOP button is green.

The following conditions must be met for the start engine light to change to green. If any of the conditions are not met, the light will be red.

**NOTE:** *The engine oil light will be on until the engine starts. If the light does not go off in 10 seconds after the engine starts, the engine will stop.*

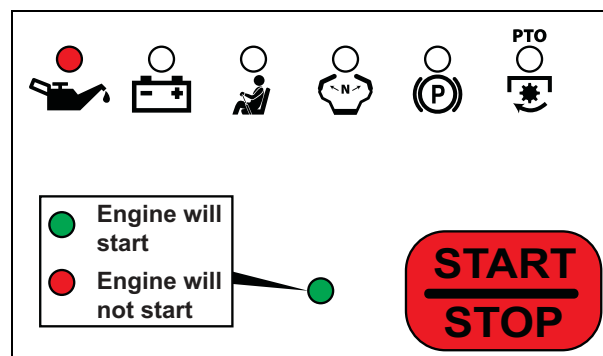

- The start-up code must be correctly entered
- The operator must be in the seat (Operator presence light is OFF)
- The parking brake must be engaged (Parking brake light is OFF)
- The steering levers must be in the neutral position (Neutral light is OFF)
- The PTO switch in the OFF (down) position (PTO switch light is OFF)

When the start engine light is green, press and hold both sides of the START/STOP button to start the engine. Release the switch when the engine starts.

**NOTE:** *There are two switches under the START/STOP button. Both switches must be pressed to start the engine. Only one switch needs to be pressed to stop the engine.*

To stop the engine, press and release the START/STOP button.

## 5.3.3.8 Mower Deck Lift/Lower Buttons

The mower deck lift lower buttons are used to lift or lower the deck when the optional electric deck lift accessory is installed. Press and hold the lift button to lift the deck. Press and hold the lower button to lower the deck.

**NOTE:** *The electric deck lift is an optional accessory. The buttons will not function unless the electric deck lift accessory is installed.*

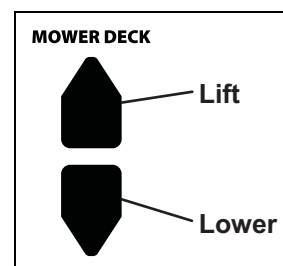

## 5 CONTROLS

### 5.3.3.9 Alarms

**Bypassed or Failed Safety Interlocks** - When the display panel detects a failed or bypassed switch, the indicator light for that switch will turn on and **SEAT BRAKE DRIVE INTLK FAULT** will flash on the display. The console will allow the mower to operate for a short time after detecting the fault to return the mower to the service area to be repaired. The engine operation will be disabled until the display panel detects the switch in the open position.

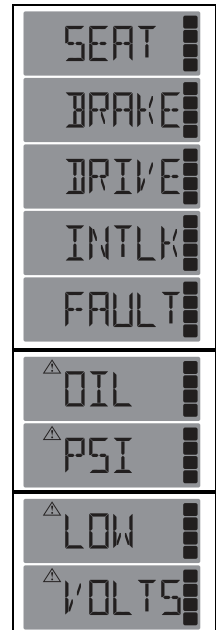

**Low Oil Alarm** - When low oil pressure is detected for 10 seconds with the engine running, **OIL PSI** will be displayed and the engine oil light will flash. Shut down the mower to reset the alarm. Do not operate the engine with the oil pressure light on.

**Low Voltage Alarm** - If the panel detects system voltage below 12 VDC for 90 seconds, **LOW VOLTS** will be on the display and the battery voltage light will flash. The alarm is reset when system voltage rises above 12 VDC or the mower is shut down.

### 5.3.3.10 Changing the start-up code

The start-up code can be changed by the owner. Record your new start-up code. Only a Dixie Chopper Dealer can reset a forgotten start-up code. The start-up code must be between 1 and 12 digits. Example code of 43214 is shown.

To change the start-up code, the engine must be stopped and the PTO switch in the OFF (Down) position.

1. Enter the current start-up code.
2. Hold the one (1) and two (2) buttons down until **CHNGE CODE** is shown, followed by a blank screen.
3. Enter the new code into the module using the one (1), two (2), three (3) and four (4) buttons. If the code is more than five digits long, only the last five digits pressed will be shown.
4. Pull up on the PTO switch. If the new code is accepted the message **ENTER CODE AGAIN** will be displayed. Reenter the new code and push the PTO switch down.
5. If the new code is entered correctly both times, **SAVED CODE** will be displayed and the new code is active. If the code is not entered correctly the second time, **NO MATCH** is shown and the process must be started again.

Some code combinations are not usable. If the new code is not usable, **BAD CODE** will be displayed when the PTO switch is pulled up. Push the PTO switch down and start the process again with a different code.

If more than 12 digits are entered, the display will show **FULL**. Only the first twelve digits pressed are accepted.

If the PTO switch is pulled up without entering a code, **EMPTY CODE** is shown and the process must be started again.

If a button is not pressed for 10 seconds, **TIME OUT** will be displayed and the process must be started again.

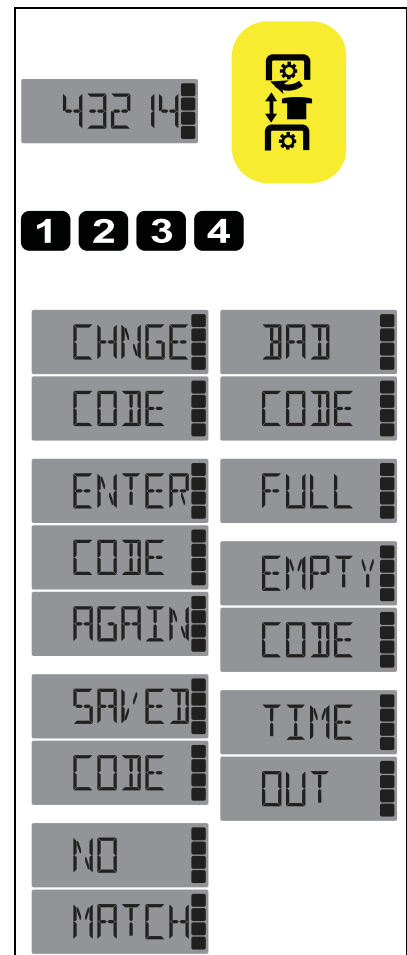



## 5.4 PARKING BRAKE

The parking brake lever engages the rear drive axle brakes to prevent movement of the mower.

When the steering control levers are in the Neutral position, push the button in and pull the parking brake lever up to the engaged position to engage the parking brake. Push the button in and push the parking brake lever down to the disengaged position to disengage the parking brake.

The steering control levers must be in the Neutral position, the PTO switch must be in the OFF (down) position and the parking brake engaged to start the mower.

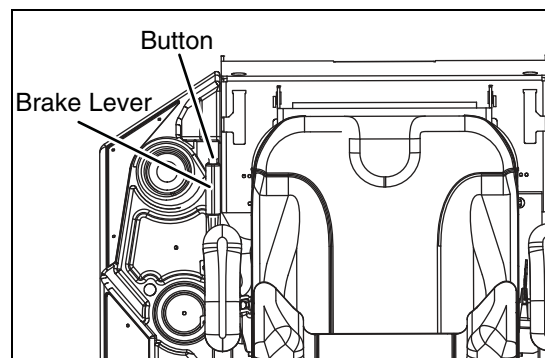

## 5.5 STEERING CONTROL LEVERS

The mower has separate drive axles for each rear wheel. The right-side control lever controls the operation of the right-side drive axle. The left-side control lever controls the operation of the left-side drive axle. **See 6.6** for the operation of the steering control levers.

DANGER

To prevent personal injury or death, do not quickly move the steering control levers or suddenly start and stop the mower. You must use more caution when you turn the mower or when you operate on slopes.

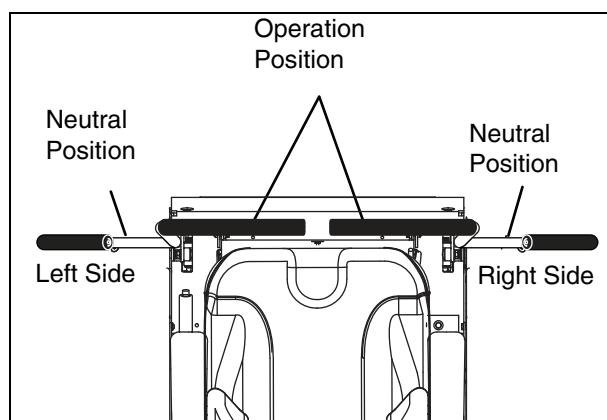

To put the steering control levers in the Neutral position, move the steering control levers toward the left and right sides.

The steering control levers must be in the Neutral position, the PTO switch must be in the OFF (down) position and the parking brake engaged to start the mower.

## 5.6 CUTTING UNIT HOC PEDAL

The cutting unit height of cut (HOC) pedal lifts and lowers the cutting unit.

Install the HOC Pin in the correct position for the cutting height. To lower the cutting unit, press the pedal down, push the lift stop lever forward and slowly allow the pedal to lift until the HOC mechanism touches the HOC Pin. **See 6.7** for the HOC plate position chart.

NOTICE

To prevent damage to the HOC mechanism or the cutting unit, slowly allow the pedal to lift until the HOC mechanism touches the HOC pin. Do not allow the cutting unit to drop from the lifted position against the HOC pin.

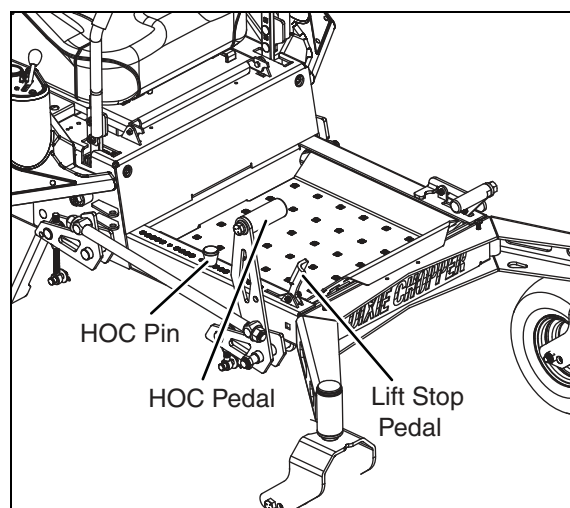

To lift the cutting unit, fully push the HOC pedal. Release the lift pedal.

## 5 CONTROLS

### 5.7 LIFT STOP PEDAL

The lift stop pedal is used to hold the cutting unit in the fully raised position.

To lift the cutting unit, fully push the HOC pedal. Release the lift pedal. The lift stop pedal will hold the cutting unit in the fully raised position.

To lower the cutting unit, push on the pedal to release the pressure on the lift stop pedal and push the lift stop lever forward. When the cutting unit is lowered, the HOC mechanism will contact the HOC Pin.

### 5.8 OPERATOR CONTROLLED DISCHARGE CHUTE

The operator controlled discharge chute (OCDC) pedal opens and closes the discharge chute. When you mow around flower beds or edges of paths, the discharge chute can be closed to limit the discharge. Never mow with the discharge deflector removed.



#### WARNING

The operator must be careful of persons and objects near the mower. Do not release the cut grass in the direction of persons or allow persons near the mower while in operation.

Never operate the mover with the discharge chute removed. The cutting unit can discharge objects for long distances with the discharge chute removed. Remember that the operator and/or owner are responsible for accidents or hazards that occur to other persons or their property.

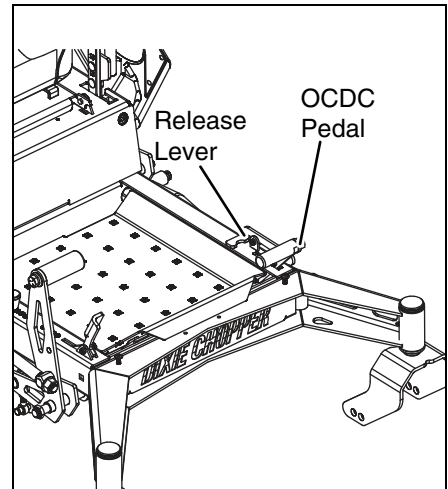

The OCDC discharge pedal will keep the chute in the fully open or fully closed position.

To close the OCDC chute, put your foot on the OCDC pedal, fully depress the pedal until the lock engages in the forward position to lock the OCDC in the closed position.

The OCDC is normally open. If the OCDC is locked closed then you need to put your foot on the OCDC pedal, fully depress the pedal while placing your heel on the release lever to release it so that the OCDC pedal can come back to the standard open position.

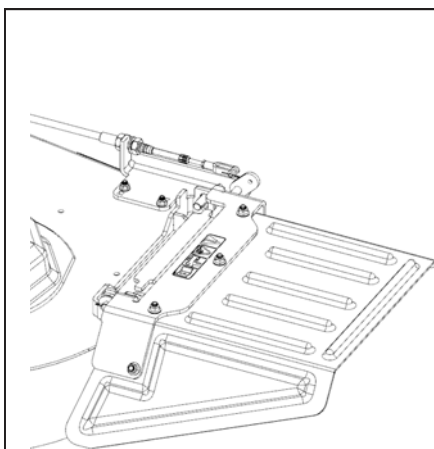

Chute deflector must be in down position during operation

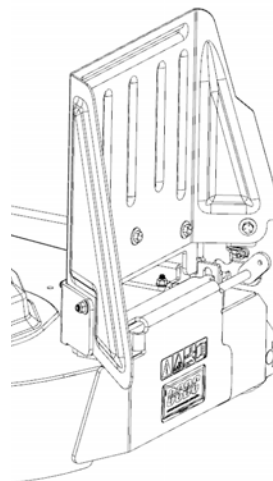

Chute deflector up position is for transportation purpose only

## 6.1 DAILY INSPECTION

---

 **CAUTION**

The inspection must be done each day when the engine is turned off and all fluids are cold. Lower the cutting units to the ground, engage the parking brake, stop the engine and remove the ignition key.

Do a visual inspection of the mower. Look for indications of wear or loose hardware. Look for any components that are not included on the mower or damaged components. Check for fuel and oil leaks to make sure the connections are tight. Make sure that all hoses are in good condition.

Check the fuel supply and crankcase oil level. When the engine is cold, all fluids must be at the full level mark.

Check the engine oil cooler fins for dirt or grass. Clean with compressed air as required before you operate the mower.

Check all tires for the correct pressure.

Test the Interlock system.

## 6 OPERATION

### 6.2 INTERLOCK SYSTEM

#### 6.2.1 BLACKHAWK MODELS INTERLOCK SYSTEM

The BlackHawk Interlock System prevents the engine to start unless the steering control levers are in the Neutral position and the PTO switch is in the OFF (Down) position. The system stops the engine if the operator leaves the seat with the PTO switch in the ON position, steering control levers out of the NEUTRAL position or the parking brake disengaged.



### WARNING

Do not operate the equipment with the Interlock System disconnected or the system does not operate correctly. Do not disconnect or prevent the operation of any switch.

Do each of these tests to make sure the Interlock System operates correctly. If any of the tests fail, stop the test and have the system inspected and repaired as shown below:

- The engine does not start during test 1
- The engine does start during tests 2, 3 and 4
- The engine continues to run during tests 5 and 6

Refer to the chart below for each test and follow the check (4) marks across the chart. Turn off the engine between each test.

TEST 1: The test shows the recommended engine start procedure. The operator is in the seat, parking brake is engaged, the steering control levers are in the NEUTRAL position and the PTO switch is in the OFF (down) position. The engine will start.

**NOTE:** *The engine will also start with the parking brake engaged, the steering control levers are in the NEUTRAL position the PTO switch is in the OFF (down) position and the operator out of the seat.*

TEST 2: The engine must not start if the PTO switch is in the ON position.

TEST 3: The engine must not start if the parking brake is disengaged and the operator is out of the seat.

**NOTE:** *The engine will start when the operator in the seat, the steering control levers are in the NEUTRAL position the PTO switch is in the OFF (down) position and the parking brake disengaged.*

TEST 4: The engine must not start if the steering control levers are out of the NEUTRAL position.

TEST 5: Start the engine with the normal procedure. Turn on the PTO switch and lift your weight off the seat. The engine must stop. The cutting unit blades must not rotate after seven (7) seconds.

TEST 6: Start the engine with the normal procedure. Disengage the parking brake and lift your weight off the seat. The engine must stop. The cutting unit blades must not rotate after seven (7) seconds.

Test	Operator Seated		PTO Switch OFF		Parking Brake Engaged		Steering Control Levers in Neutral		Engine Starts	
	Yes	No	Yes	No	Yes	No	Yes	No	Yes	No
1	4		4		4		4		4	
2	4			4	4		4			4
3		4	4			4	4			4
4	4		4		4			4		4
5	4	H	4	H	4		4		H	
6	4	H	4		4	H	4		H	

H Start the engine with the normal procedure, move position of the switch and lift your weight off the seat. The engine must stop immediately and the cutting unit blades must not rotate after seven (7) seconds.

**6.2.2 BLACKHAWK HP MODELS INTERLOCK SYSTEM**

The BlackHawk HP Interlock System prevents the engine to start unless the operator is in the seat, steering control levers are in the Neutral position, the parking brake is engaged and the PTO switch is in the OFF (Down) position. The system stops the engine if the operator leaves the seat with the PTO switch in the ON position, steering control levers out of the NEUTRAL position or the parking brake disengaged.



Do not operate the equipment with the Interlock System disconnected or the system does not operate correctly. Do not disconnect or prevent the operation of any switch.

Do each of these tests to make sure the Interlock System operates correctly. If any of the tests fail, stop the test and have the system inspected and repaired as shown below:

- The engine does not start during test 1
- The engine does start during tests 2, 3 and 4
- The engine continues to run during tests 5 and 6

Refer to the chart below for each test and follow the check (4) marks across the chart. Turn off the engine between each test.

TEST 1: The test shows the normal engine start procedure. The operator is in the seat, parking brake is engaged, the steering control levers are in the NEUTRAL position and the PTO switch is in the OFF (down) position. The engine will start.

TEST 2: The engine must not start if the PTO switch is in the ON position.

TEST 3: The engine must not start if the parking brake is disengaged.

TEST 4: The engine must not start if the steering control lever(s) is out of the NEUTRAL position.

TEST 5: Start the engine with the normal procedure. Turn on the PTO switch and lift your weight off the seat. The engine must stop. The cutting unit blades must not rotate after seven (7) seconds.

TEST 6: Start the engine with the normal procedure. Disengage the parking brake and lift your weight off the seat. The engine must stop. The cutting unit blades must not rotate after seven (7) seconds.

Test	Operator Seated		PTO Switch OFF		Parking Brake Engaged		Steering Control Levers in Neutral		Engine Starts	
	Yes	No	Yes	No	Yes	No	Yes	No	Yes	No
1	4		4		4		4		4	
2	4			4	4		4			4
3	4		4			4	4			4
4	4		4		4			4		4
5	4	H	4	H	4		4		H	
6	4	H	4		4	H	4		H	

H Start the engine with the normal procedure, move position of the switch and lift your weight off the seat. The engine must stop immediately and the cutting unit blades must not rotate after seven (7) seconds.

## 6 OPERATION

### 6.3 OPERATING PROCEDURE

#### **WARNING**

This mower has a folding Roll Over Protection Structure (ROPS). Always wear the seat belt with the ROPS frame in the vertical and locked position. Never wear the seat belt with the ROPS in the folded position.

If the mower is over turning and the ROPS is in the vertical and locked position, hold the steering wheel. Do not try to move off the mower or leave the seat.

#### **CAUTION**

To prevent injury, always wear the safety glasses, leather work shoes or boots, a hard hat and ear protection.

1. Always start the engine with the operator in the seat, never while next to the mower. Never start the engine with persons near the mower.
2. Never operate the engine without enough ventilation or in an enclosed area. The carbon monoxide in the exhaust fumes can increase to dangerous levels.
3. **BlackHawk Models:** If the low engine oil pressure alarm turns on, shut down the mower immediately. Inspect the oil level in the engine. If the alarm remains on with the oil at proper level, shut off the engine and tow or trailer the mower back to a service area. NEVER operate the engine with the alarm on, severe damage to the engine can occur.  
**BlackHawk HP Models:** If the low engine oil pressure light turns on, shut down the mower immediately. Inspect the oil level in the engine. If the oil light remains on with the oil at proper level, shut off engine and tow or trailer the mower back to a service area. NEVER operate the engine with the oil light on, severe damage to the engine can occur.
4. Keep your hands and feet away from moving parts and the cutting units. When possible, do not adjust the mower with the engine started.
5. Do not operate the mower with loose or damaged components. All components must be correctly fastened to the mower. Mow when the grass is dry to get the best results.
6. First cut in a test area so that you completely understand the operation of the tractor and controls.
7. Inspect the area to find the safest procedure for the mower. Check the height of the grass, the type of terrain and the conditions of the surface. Each condition needs the correct adjustments and precautions.
8. Do not release the cut grass in the direction of persons or allow persons near the mower while in operation. The owner and operator are responsible for injuries caused to persons near the mower and any damage to their property.

#### **WARNING**

Remove all objects you can find before you operate the mower. Carefully enter a new area and always operate at speeds that allow you to control the mower safely.

Before you clean, adjust or repair this equipment, always turn off the PTO switch, lower the cutting unit to the ground, turn on the parking brake switch, stop the engine and remove the ignition key.

9. Be careful when you operate near to gravel areas (roads, parking areas, cart paths). Stones released from the equipment can cause injuries to persons and cause damage to the equipment.
10. When you are not mowing grass, always turn off the PTO switch.
11. Before you move across or operate on the paths or roads, turn off the PTO switch, lift the cutting unit and travel at decreased speed. Look for traffic.
12. When you hit an object or mower starts to cause vibration that is not normal, inspect the mower for damage and make repairs.
13. Travel at decreased speed and be careful when you operate on the slopes or near sharp edges.
14. When you drive in the reverse direction, look behind you and down to make sure the path is clear. Use caution when you go near corners, trees or other objects that can prevent a clear view.
15. Never use your hands to clean the cutting units. Use a brush to remove the grass clippings from the blades. The blades are sharp and can cause injuries.

## 6.4 STARTING THE ENGINE

Start the engine with the operator in the seat, steering controls levers in the Neutral position, the PTO switch in the OFF position and the parking brake engaged.

Set the throttle lever to half throttle.

**Kawasaki Engines:** If the engine is cold, move the choke to the choke position.

**BlackHawk Models** - Turn the ignition switch to the RUN position. The hour meter will show the engine operation hours.

**BlackHawk HP Models** - Enter the start-up code. **See 5.3.3.1**

**BlackHawk Models** - Turn the ignition switch to the START position. Release the key when the engine starts. Allow 30 seconds between start tries to allow the starter motor to become cool.

**BlackHawk HP Models** - Press and hold both sides of the START/STOP button. Release the button when the engine starts. Allow 30 seconds between start tries to allow the starter motor to become cool. **See 5.3.3.7**

### NOTICE

Do not hold the ignition switch in the START position for more than 5 seconds.

When the engine starts, if equipped move the choke to the RUN position. Allow the engine to become warm before you operate the engine at full throttle.

## 6.5 TO STOP THE ENGINE

To stop and park the mower in normal conditions:

1. Turn the PTO switch to the OFF position. Drive the mower to a flat and level area to park the mower.
2. Put the steering control levers in the Neutral position.
3. Lower the cutting unit to the ground. Engage the parking brake.
4. **BlackHawk Models** - Turn the ignition switch to the OFF position and remove the key before you leave the mower.  
**BlackHawk HP Models** - Press the START/STOP button to stop the engine. System will shut down 15 seconds after the operator leaves the seat.

If an emergency occurs and you must park the mower in the area of operation, follow the guidelines set by the grounds manager. If the mower is parked on a slope, chock or block the wheels.

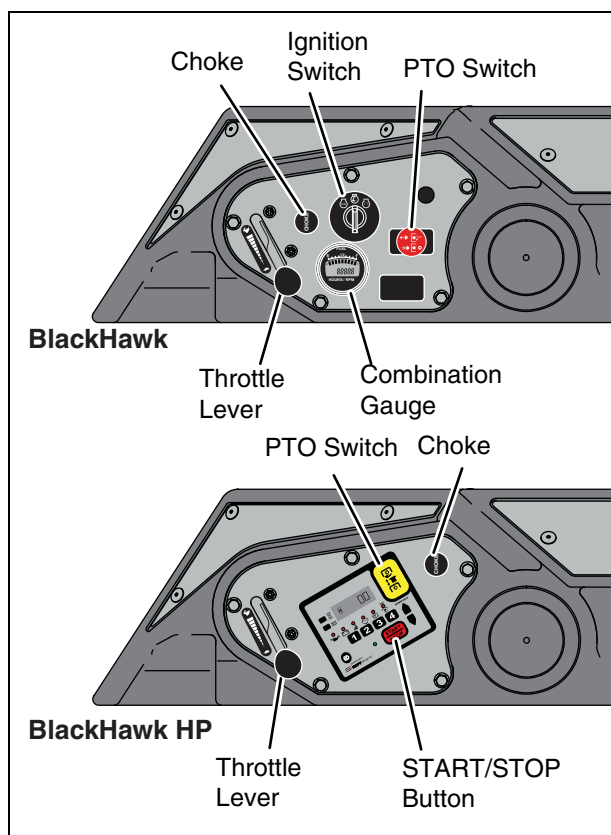

## 6 OPERATION

### 6.6 DRIVING

Read and follow all safety instructions contained in this manual when you operate the mower. When you operate in the reverse direction, look behind you to make sure you have a clear path. Do not mow in reverse.

Slowly and equally push both the right-side and left-side control levers forward to drive the mower in the forward direction. The more the levers are pressed the more the forward speed is increased.

### DANGER

To prevent personal injury or death, do not quickly move the steering control levers or suddenly start and stop the mower. You must use more caution when you turn the mower or when you operate on slopes.

Slowly and equally pull both the right-side and left-side control levers toward you to drive the mower in the reverse direction. The more the levers are pulled the more the reverse speed is increased. Press the levers against the reverse stop for the maximum reverse speed.

To turn the mower to the left, push the right-side drive lever more than the left-side drive lever. The greater the difference in lever position, the sharper the mower will turn. To do a zero radius left turn, press the right-side lever forward and pull the left-side lever toward you.

To turn the mower to the right, push the left-side drive lever more than the right-side drive lever. The greater the difference in lever position, the sharper the mower will turn. To do a zero radius right turn, press the left-side lever forward and pull the right-side lever toward you.

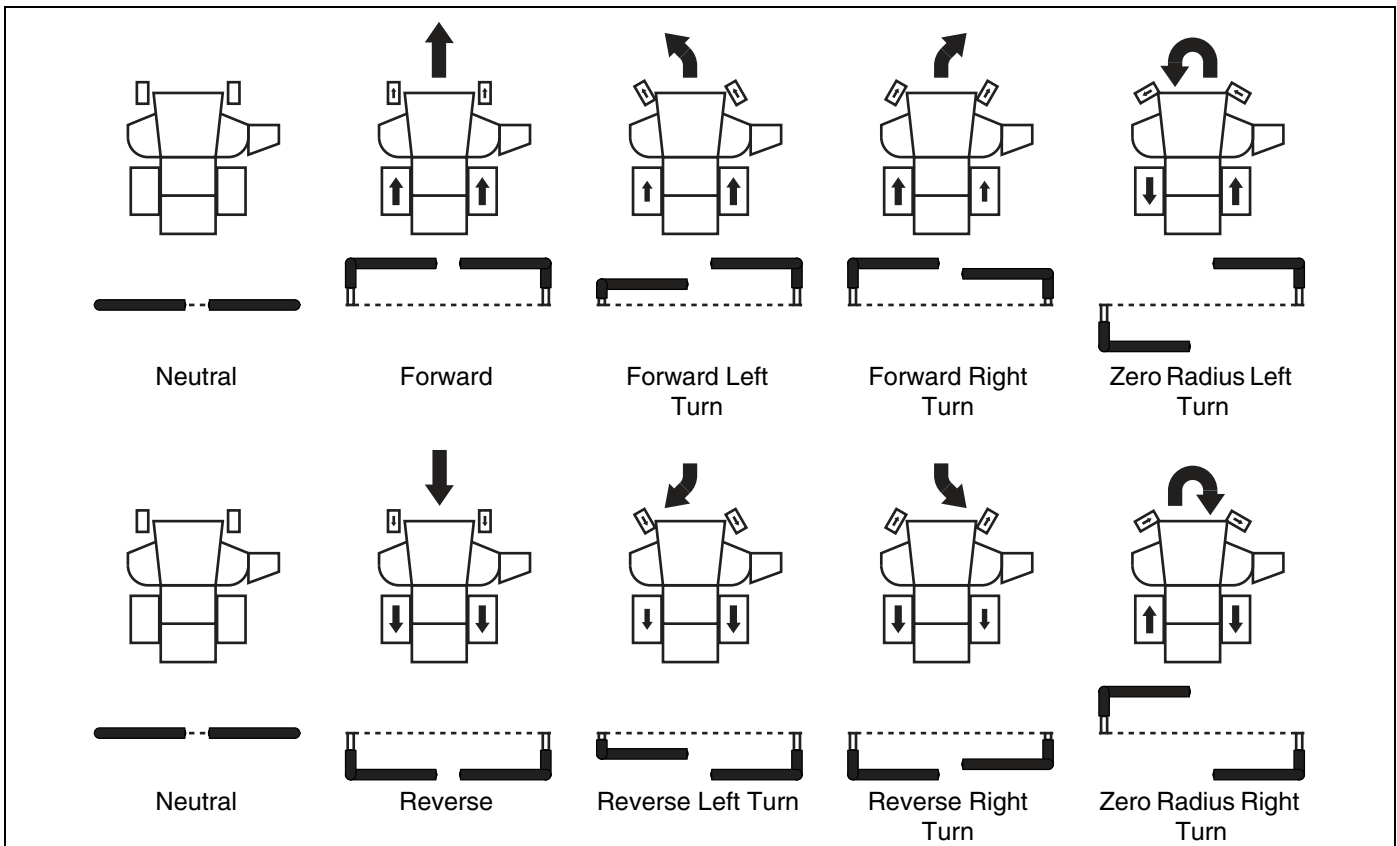



## 6.7 HEIGHT OF CUT

The height of cut is determined by the position of the HOC pin. Engage the parking brake, stop the engine and remove the key before you change the HOC. Fully raise the cutting unit.

Use the chart to find the correct cutting height hole for the necessary HOC.

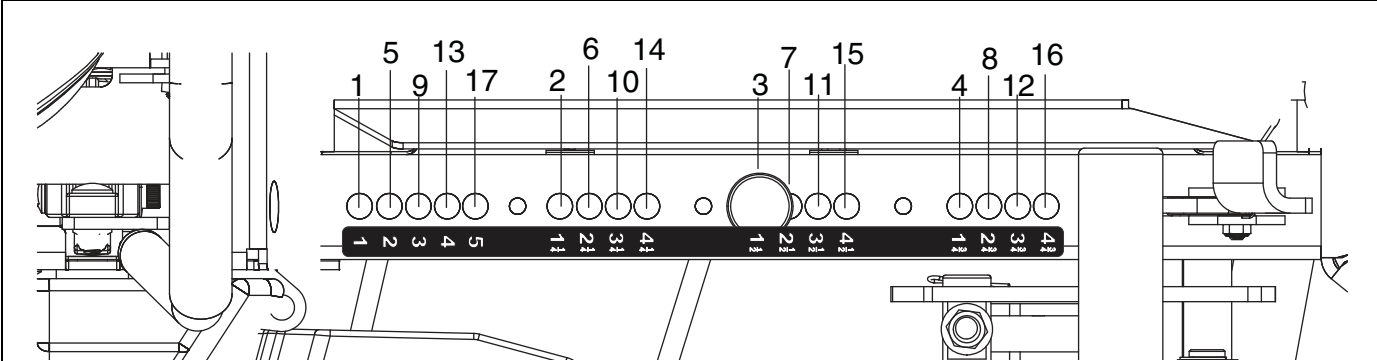

Hole	HOC	Hole	HOC
1	1 Inch (2.5 cm)	10	3-1/4 Inch (8.3 cm)
2	1-1/4 Inch (3.2 cm)	11	3-1/2 Inch (8.9 cm)
3	1-1/2 Inch (3.8 cm)	12	3-3/4 Inch (9.5 cm)
4	1-3/4 Inch (4.4 cm)	13	4 Inch (10.2 cm)
5	2 Inch (5.1 cm)	14	4-1/4 Inch (10.8 cm)
6	2-1/4 Inch (5.7 cm)	15	4-1/2 Inch (11.4 cm)
7	2-1/2 Inch (6.4 cm)	16	4-3/4 Inch (12.1 cm)
8	2-3/4 Inch (7.0 cm)	17	5 Inch (12.7 cm)
9	3 Inch (7.6 cm)		

## 6.8 MOWING

### **WARNING**

To prevent injuries, when the blades rotate, keep your hands, feet and clothing away from the cutting unit.

**NEVER** use your hands to clean the cutting unit. Use a brush to remove grass from the blades. The blades can be sharp and can cause injury.

**DO NOT** operate the cutting unit with the discharge chute removed.

To mow:

1. Put the PTO switch in the ON position. The blades will start turning.
2. Lower the cutting unit.
3. Push the steering control levers forward to drive the mower. Never mow in the reverse direction.
4. Slow down when you turn the mower or mow on slopes.

# 6 OPERATION

## 6.9 MOWING ON SLOPES

The mower is made to have good traction and to have good balance. Operate the mower with caution when you drive on a slope. If you drive on wet grass, the traction and steering control of the mower is decreased.

**WARNING**

To make sure that the mower does not turn over, the safest method to drive on a slope is to drive vertically. Travel at a slow speed and do not make turns that are not necessary.

Check for hazards on the road that are not visible to the drivers. Keep the cutting unit lowered when you operate on the slopes.

**CAUTION**

When you are mowing on sides of hills, do not operate the mower on slopes greater than 5° or a 8.7% grade.

When you are mowing going uphill, do not operate the mower on slopes greater than 10° or a 17.6% grade.

When you are mowing going downhill, do not operate the mower on slopes greater than 15° or a 26.8% grade.

1. Always cut the grass with the engine at full throttle. Control the forward speed with the steering control levers to keep the correct performance.
2. If the mower moves to the side or the tires damage the turf, drive the mower on a slope with a decreased angle.
3. If the mower continues to move to the side and damage the turf, the slope is at an angle that is not safe. Do not continue to drive toward the top of the slope. Carefully drive toward the bottom of the slope.
4. When you drive toward the bottom of a slope with a high angle, lower the cutting unit to the ground. This procedure makes sure the mower does not turn upside down.
5. Correct tire pressure is necessary for maximum traction.
  - Rear - 8-10 psi (0.55-0.69 BAR)
  - Front - 12-15 psi (0.83-1.03 BAR)

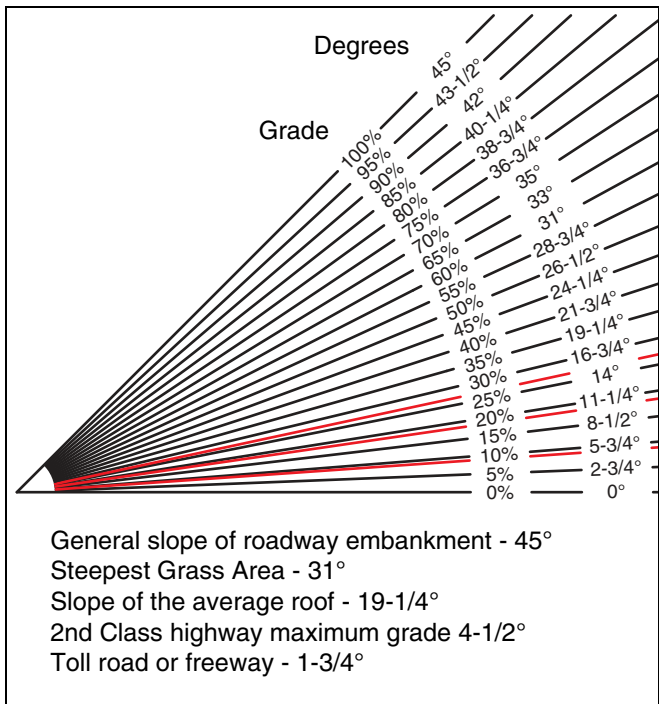
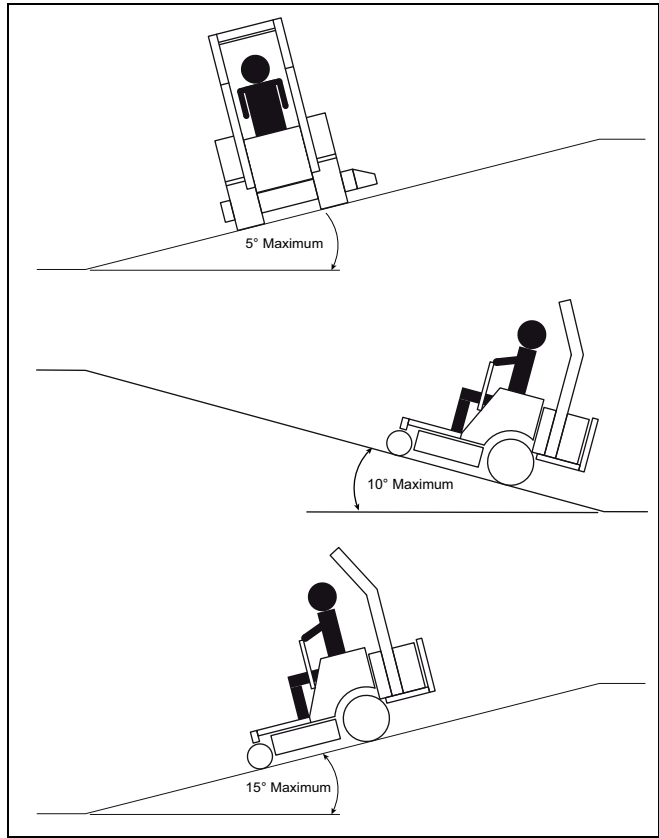

## How to calculate a slope:

Tools Required:

Level **(A)**, either 1 yard, or 1 meter long.

Tape measure **(B)**.

Use the level **(A)** and position it horizontally to measure the distance **(C)** with tape measure **(B)**. Use the chart to calculate the slope angle or the percentage grade of the slope **(D)**.

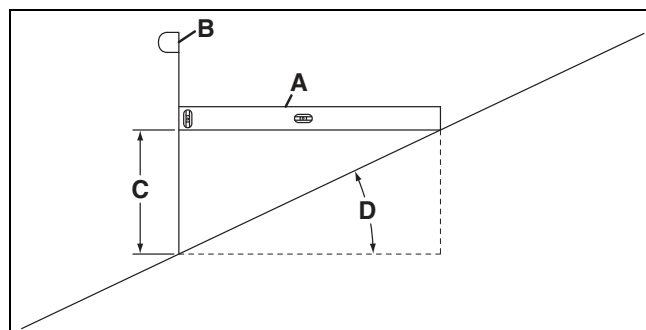

Height (C)		Result (D)	
Inches with 1 Yard Level (A)	Millimeters with 1 Meter Level (A)	Slope in Degrees	Slope Grade %
3		4.8	8.3
	100	5.7	10.0
	150	8.5	15
6		9.5	16.7
	200	11.3	20.0
7.5		11.8	20.8
	225	12.7	22.5
9		14	25.0
	275	15.4	27.5
10		15.5	27.8
	300	16.7	30.0
11		17.0	30.6
	325	18.0	32.5
12		18.4	33.3
	350	19.3	35.0
13		19.9	36.1
	375	20.6	37.5
14		21.3	38.9
	400	21.8	40.0
15		22.6	41.7
	425	23.0	42.5
16		24	44.4
	475	25.4	47.5
18		26.6	50.0
	500		
20		29.1	55.6
	600	31.0	60.0
25		34.8	69.4
	800	38.7	80.0
30		39.8	83.3
	900	42.0	90
36		45.0	100
	1000		

## 6 OPERATION

---

### 6.10 TOWING THE MOWER

---

If the mower has a problem and can not drive to the service area, open the bypass valve and load the mower on a trailer. If a trailer is not available, tow the mower at a slow speed for short distances.

Be careful when you load or unload the mower on the trailer. Fasten the mower to the trailer to prevent the mower to move on the trailer. Engage the parking brake.

If the trailer is moved on the highway, inflate the tires to the maximum pressure recorded on the tire before you fasten the mower to the trailer. Decrease the tire pressure after the mower is removed from the trailer.

Open the bypass valve on both drive axles before you tow the mower. The bypass valve lets the mower be moved without the engine started and to prevent possible damage to drive axle components.

The bypass valve is found on the front side of the left and right drive axles. To open the valve, turn the lever 90° in the direction indicated by the arrow.

Before towing, disengage the parking brake and make sure the cutting unit is lifted.

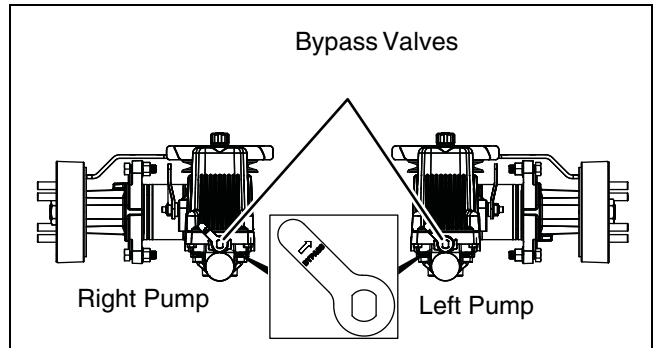

### NOTICE

When you tow the mower, do not drive more than 2 mph (3.2 km/hr). Dixie Chopper recommends that you do not tow the mower for long distances.

When the mower gets to the service area, engage the parking brake and close the bypass valves.

# MAINTENANCE AND LUBRICATION CHARTS 7

## 7.1 MAINTENANCE CHART

<b>Mower Service Interval Chart</b>		
<b>Interval</b>	<b>Item</b>	<b>Section</b>
First 8 Hours	<ul style="list-style-type: none"> <li>• Check electrical wiring</li> </ul>	<b>See 8.16</b>
Each day (10 Hours)	<ul style="list-style-type: none"> <li>• Check Safety Interlock System</li> <li>• Check engine oil level</li> <li>• Clean engine oil cooler</li> <li>• Check drive axle oil level</li> <li>• Clean area around muffler and controls</li> </ul>	<b>See 6.2</b> <b>See 8.3</b>
Each 25 Hours	<ul style="list-style-type: none"> <li>• Clean air filter foam pre-cleaner if equipped (Kawasaki Engine)<sup>1</sup></li> <li>• Replace air filter element (Kohler)<sup>1</sup></li> </ul>	<b>See 8.4</b> <b>See 8.4</b>
Each week (50 Hours)	<ul style="list-style-type: none"> <li>• Check fuel lines and fittings</li> <li>• Inspect parking brake and steering control lever linkage</li> <li>• Inspect deck and drive belts</li> <li>• Check for loose components</li> <li>• Lubricate grease fittings</li> </ul>	<b>See 8.6</b>  <b>See 7.2</b>
Each Two weeks (100 Hours)	<ul style="list-style-type: none"> <li>• Clean engine oil cooler fins and cylinder cooling fins<sup>1</sup></li> <li>• Check engine exhaust system</li> <li>• Replace engine oil and filter<sup>1</sup></li> <li>• Clean and regap spark plugs (Kawasaki Engine)</li> </ul>	<b>See 8.13</b> <b>See 8.5</b> <b>See 8.3</b>
Each month (200 Hours)	<ul style="list-style-type: none"> <li>• Check electrical wiring</li> <li>• Replace EFI fuel filter (Kohler Engine)<sup>1</sup></li> <li>• Replace primary air filter element (Kawasaki Engine)<sup>1</sup></li> <li>• Check secondary air filter element (Kawasaki Engine)<sup>1</sup></li> </ul>	<b>See 8.16</b>
300 Hours	<ul style="list-style-type: none"> <li>• Clean combustion chamber (Kawasaki Engine)<sup>2</sup></li> <li>• Check and adjust valve clearance (Kawasaki Engine)<sup>2</sup></li> <li>• Clean and lap valve seating surface (Kawasaki Engine)<sup>2</sup></li> </ul>	
Each two months (400 Hours)	<ul style="list-style-type: none"> <li>• Replace fuel filter</li> </ul>	
Yearly or 500 Hours	<ul style="list-style-type: none"> <li>• Replace secondary air filter element<sup>1</sup></li> <li>• Replace spark plugs<sup>1</sup></li> </ul>	<b>See 8.4</b>
500 Hours	<ul style="list-style-type: none"> <li>• Check and adjust valve lash (Kohler Engines)<sup>3</sup></li> </ul>	
1000 Hours	<ul style="list-style-type: none"> <li>• Replace drive axle fluid and filter (Two per mower)</li> </ul>	<b>See 8.11</b>

<sup>1</sup> Perform more frequently under severe, dusty, dirty conditions.

<sup>2</sup> Have a Kawasaki authorized dealer perform this service

<sup>3</sup> Have a Kohler authorized dealer perform this service

# 7 MAINTENANCE AND LUBRICATION CHARTS

## 7.2 LUBRICATION CHART

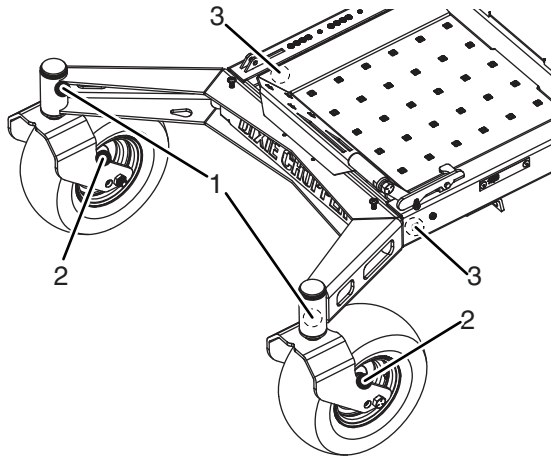

**Grease Fittings**

1. Front Wheel Pivot (2)      2. Front Wheel Bearings (2)      3. Lift Pivot Saddle (2)

## 7.3 FLUID REQUIREMENTS

Fluid Requirements		
	Quantity	Type
Engine Oil with Filter	2.2 quarts (2.08 l) (Kawasaki) 2.0 quarts (1.9 l) (Kohler)	Varies depending on air temperature. <b>See 3.6</b>
Drive Axle with Filters	Approximately 1.52 quarts (1.44 liter) each drive axle	<b>Parker HT-1000</b> 903450 - HT - 1000 Fluid (case of 12 quarts) 903452 - HT - 1000 Fluid (case of 3 gallons) 903458 - Kit - Oil Change, Parker HTE & HTJ
Fuel	6.8 U.S. Gallons (25.7 l)	87 Octane Gasoline Maximum 10% Ethanol

## 8.1 GENERAL PRECAUTIONS



### WARNING

Before you clean, adjust or repair this equipment, push PTO switch to the OFF position, lower the cutting unit, engage the parking brake, stop the engine and remove the key.

Make sure the mower is parked on a solid and level surface. Never work on a mower that is lifted only by the jack. Always use the jack stands.

A qualified technician must always do adjustments and maintenance. If the correct adjustments can not be made, contact your Dixie Chopper Dealer.

Inspect the equipment according to the maintenance schedule and keep complete records.

- a Keep the equipment clean.
- b Keep all moving parts correctly adjusted and lubricated.
- c Replace worn or damaged parts before you operate the mower.
- d Keep all fluids at the correct level.
- e Keep the shields in position and all hardware tight.
- f Keep the tires correctly inflated.

When you make the adjustments or repairs, do not wear jewelry or loose fitting clothing.

Refer to the illustrations in the Parts Manual for the removal and assembly of parts.

When you discard hazardous materials (batteries, lubricants, fuel, anti-freeze), follow your local, state or federal-recommended procedures.

## 8.2 ENGINE

**IMPORTANT** - The mower includes a separate Engine Manual prepared by the engine manufacturer. Read the Engine Manual and know the operation and maintenance of the engine. When you follow the engine manufacturer instructions, you will make sure of the maximum service life of the engine. The replacement engine manuals are available from the engine manufacturer.

The operation and maintenance during the first 8 hours of a new engine can make a difference to the performance and life of the engine.

During the first 8 hours of operation, Dixie Chopper recommends the following.

- Allow the engine to reach a temperature of at least 140° F (60° C) before operation at full load.
- Check the engine oil level two times each day. Higher than normal oil use can occur during the first 8 hours.
- Change the engine oil and oil filter after the first 8 hours of operation.
- Refer to the Engine manual for specified maintenance intervals.

### NOTICE

The mower operates and cuts correctly at the preset governor setting. Do not change the engine governor setting or over speed the engine.

## 8 MAINTENANCE

### 8.3 ENGINE OIL

Check engine oil level

Check the engine oil level before you start the engine or at least five minutes after you stop the engine.

- a Park the mower on a level surface.
- b The dipstick is found at the front corner of the engine behind the seat. Remove the dipstick. Clean the dipstick with a cloth and replace in position.
- c Remove the dipstick and check the oil level. The oil level must be between the two level indicators on the dipstick.

Change Engine Oil and Filter

- a Start the engine to increase the temperature, then stop the engine.
- b Place a container capable of holding one gallon under the engine.
- c Remove the oil drain plug and allow the engine oil to drain into a container.
- d Remove the oil filter.
- e Let the engine oil flow into a container.
- f Clean the filter area on the engine.
- g Apply a thin layer of clean engine oil to the gasket on new filter. Install the oil filter.
- h Tighten the filter until the gasket contacts the oil filter adapter, then tighten an additional 1/2 to 3/4 turn. Only use your hand to tighten the filter.
- i Replace the oil drain plug and fill the engine with the correct quantity and grade of oil through the dipstick tube.
- j Start the engine and check around the oil filter gasket for leaks.
- k Stop the engine and check the engine oil level.



### CAUTION

The engine oil can damage your skin. Use gloves when you use engine oil. If engine oil touches your skin, clean the area immediately.

Discard used engine oil as shown in local regulations.

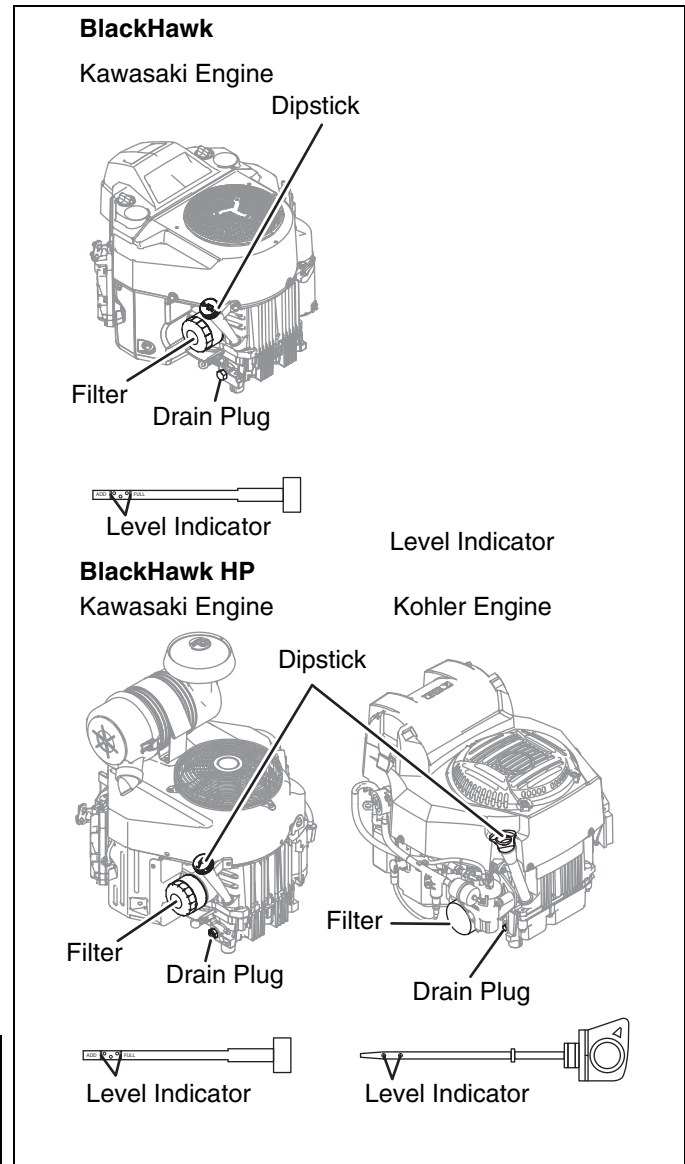



**8.4 ENGINE AIR FILTER**

Do not remove the elements to inspect or clean. Removal of the filter that is not necessary increases the risk of dust and other particles to enter the engine.

Refer to the Maintenance Chart for air filter service and replacement.

When service is needed, first clean the outside of the filter housing, then remove the outer element. Only remove the inner element if replacement is needed.

Clean the inside of the filter housing. Make sure dust and other particles do not get into the engine inlet hose.

Inspect the new elements. Do not use a damaged element and never use an incorrect element.

**BlackHawk Kawasaki Engine** - Lift the filter cover off the engine. Loosen the hose clamp and remove the filter. Install the foam pre-cleaner before you install the filter element. After you install the filter, make sure the hose clamp is tight and holds the filter in position.

**BlackHawk HP Kawasaki Engine:** Assemble the inner and outer filter elements. Make sure the elements seat correctly. Assemble the cap to the filter housing. Make sure the cap seals around the filter housing. The dust valve on the cap must be at the bottom of the filter. Fasten the cap with the two clips.

**Kohler Engine:** Lift the filter cover off the engine and remove the filter. Assemble the filter element. Make sure the element seat correctly. Assemble the filter cover to the engine.

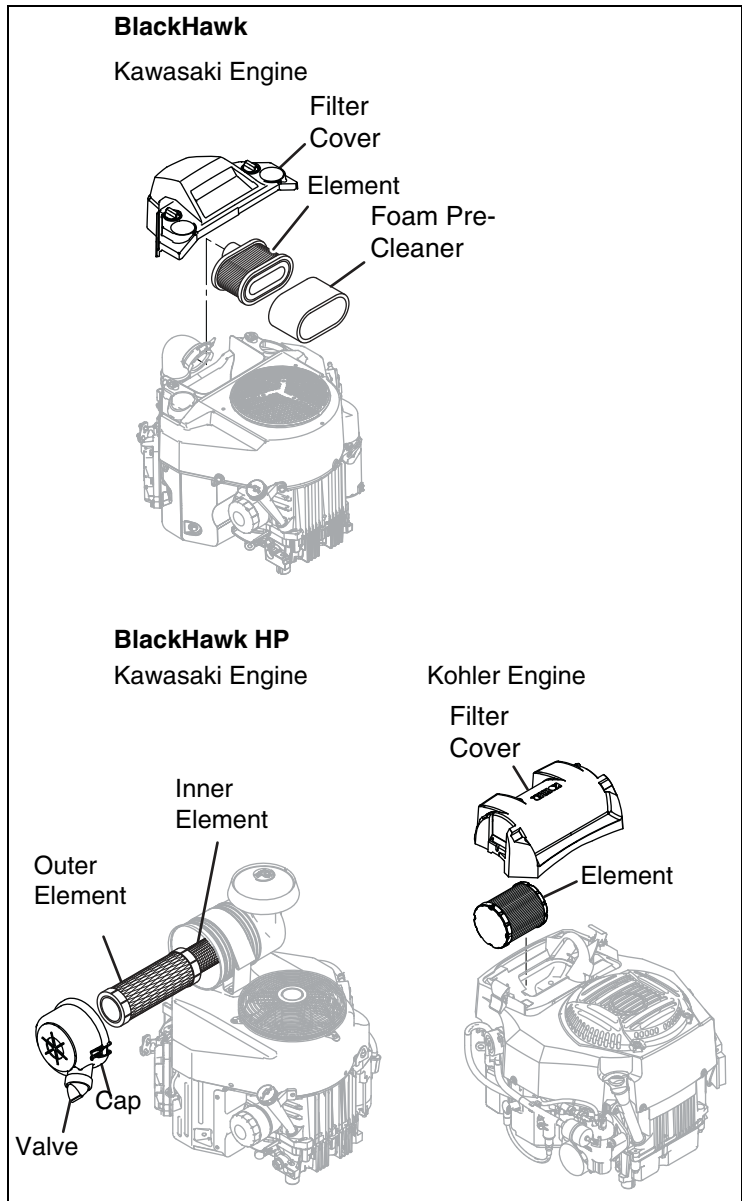

## 8 MAINTENANCE

### 8.5 ENGINE EXHAUST

#### **WARNING**

The exhaust fumes contain carbon monoxide. The carbon monoxide in the exhaust fumes can increase to dangerous levels. To protect you from carbon monoxide poisoning, inspect the complete exhaust system every month and replace damaged components immediately.

NEVER operate the engine without enough ventilation.

The temperature of the exhaust components can be greater than 300° F (149° C). To prevent the burns, do not touch a hot exhaust system.

If you sense a change in the color or sound of the exhaust, stop the engine immediately. Identify the problem and have the system repaired.

Torque all exhaust manifold hardware equally. Tighten or replace the exhaust clamps.

### 8.6 FUEL

**Gasoline is flammable. Use caution when you add the fuel to the mower.** Only use an approved container. The spout on the container must fit inside the fuel filler neck. Never use the containers that are not approved to keep or transfer fuel.

#### **WARNING**

Refuel the mower before you start the engine. When the engine is in operation or while the engine is hot, never remove the fuel cap or add fuel to the mower.

Refuel outdoors only and do not smoke when you add fuel.

If the fuel spills, do not try to start the engine, but move the mower away from the area. Until fuel vapors are removed, do not allow the sparks, open flame or other types of ignition.

Never keep fuel containers near an open flame or any device that can cause the ignition of fuel or fuel vapors.

Always tighten the fuel tank cap and container cap after you add fuel.

Only fill the fuel tank to the bottom of the filler neck. Do not overfill the fuel tank.

Do not use premium gasoline or an oil-gasoline mixture. Use clean, fresh, regular unleaded gasoline, 87 octane minimum. When using blended fuel, do not use a blend with more than 10% ethanol. Under no circumstances should you use a blend with methanol. Refer to the engine's operator manual for fuel recommendations when using blended fuel.

**NOTE:** *E15, E20 and E85 blended fuels are NOT approved and should not be used. Effects of old, stale or contaminated fuel are not covered under the warranty.*

Check fuel hoses and clamps every 50 hours. Replace fuel hoses and clamps at first indication of wear or damage.

Keep fuel according to your local, state or federal regulations and instructions from your fuel supplier.

Never allow the tank to become empty.

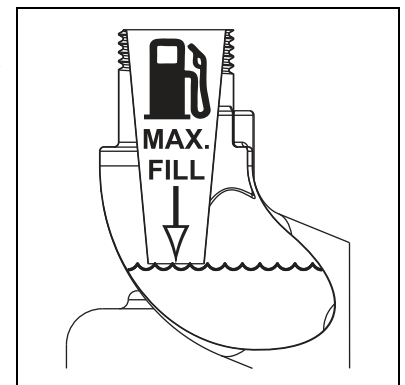

## 8.7 TIRES

Keep the tires correctly inflated to increase tire life. Inspect the tread wear.

Check the tire pressure each day, while the tires are cool. Use an accurate low-pressure tire gauge.

Keep the rear tires inflated to 8-10 psi (0.55-0.69 BAR). Keep the front tires inflated to 12-15 psi (0.83-1.03 BAR).



### **CAUTION**

DO NOT try to put a tire on a rim unless you have the correct training, tools and experience. Incorrect mounting can cause an explosion which can cause injury.

## 8.8 WHEEL MOUNTING PROCEDURE



### **WARNING**

Make sure the mower is parked on a solid and level surface. Never work on a mower that is supported only by the jack. Always use jack stands.

If only the front or behind the mower is lifted, put the chocks in front of and behind the wheels that are not lifted.

Remove dirt, grease and oil from the stud threads. Do not lubricate threads.

Put the wheel on the hub. Inspect the wheel to make sure of full contact between surface of wheel and hub.

Tighten all hardware with your fingers, then torque hardware in a criss-cross order. When possible, tighten nuts in the top position.

Check and torque hardware each day until torque is kept at 65-75 ft.lb. (88-102 Nm).

## 8.9 CHARGE THE BATTERY



### **WARNING**

Charge the battery in an area with good airflow. The battery can release hydrogen gas that is explosive. To prevent an explosion, keep any device that can cause sparks or flames away from the battery.

When the battery charger is turned on, to prevent injury, stay away from the battery. A battery that is damaged can cause an explosion.

Read the battery charger manual for specified instructions on the operation of the charger. Do not charge the battery with the ignition switch in the ON position. Always disconnect the negative battery cable when charging the battery.

When possible, remove the battery from the mower before you charge the battery. If the battery is not sealed, check and make sure the level of the electrolyte is above the plates in all of the cells.

Make sure the battery charger is turned OFF, then connect the battery charger to the battery terminals as specified in the battery charger manual.

Always turn OFF the battery charger before you disconnect the battery charger from the battery terminals.

## 8 MAINTENANCE

---

### 8.10 BATTERY

---

Before you service the battery, make sure the ignition switch is in the OFF position and the key is removed.

#### **CAUTION**

When you service the battery, always use the tools with insulation, wear protective glasses and protective clothing.  
Discard used batteries as shown in your local regulations.

#### **WARNING**

The battery contains corrosive acid. Prevent contact with the battery acid.  
Always wash your hands after you service a battery.

#### **WARNING**

The battery posts, battery terminals and related accessories contain lead and lead compounds, chemicals known to the State of California to cause cancer and other reproductive harm.

Tighten the battery cables on the battery terminals, To prevent corrosion, apply a layer of silicone dielectric grease to battery terminals and ends of cables. Keep the vent caps and battery terminal covers in position.

Before you do any welding operation on the mower, always disconnect the battery cables from the battery and the connectors from the controllers.

Confirm the battery polarity before you connect or you disconnect the battery cables. Do not allow the battery cables to touch opposing terminals. Never start the engine with loose battery cables or disconnect the battery cables with the engine in operation

When you install the battery, always connect the positive (RED) battery cable before the negative (BLACK) battery cable.

When you remove the battery, always disconnect the negative (BLACK) battery cable before the positive (RED) battery cable.

#### **Jump-Starting the Mower**

- a Before you try to jump-start the mower, check the condition of the drained battery. Never use a quick charger to start the engine.
- b Connect the positive (+) battery terminal of the charged battery to positive battery terminal of the drained battery.
- c Connect the negative (-) battery terminal of the charged battery to frame of vehicle with the drained battery.

#### **WARNING**

The battery can release hydrogen gas that is explosive. To decrease the risk of an explosion, prevent sparks near the battery. Always connect the negative jumper cable to the frame of the mower with the drained battery.

- d When the cables are connected, start the engine on the vehicle with the good battery, then start the mower.

**8.11 DRIVE AXLE FLUID**

Lift the rear wheels off the ground. Support the mower with jack stands.

**WARNING**

Make sure the mower is parked on a solid and level surface. Never work on a mower that is supported only by the jack. Always use jack stands.

Put chocks in front of and behind the front wheels.

Drain and replace the drive axle fluid and filter each 1000 hours.

Always replace the filter when you replace the drive axle fluid.

- a Clean the area around the filter plug and breather cap to prevent dirt to enter the drive axle.
- b Place a container capable of holding one gallon (4 liters) under the drive axle.
- c Remove the filter plug and the filter. Remove the breather/dipstick. Allow the fluid to drain into the container.
- d After the oil has drained, insert a new filter into to the drive axle. Assemble the filter plug to the drive axle. torque the plug to 115-135 in. lb. (13-15 Nm).
- e Fill the drive axle with proper drive axle fluid. When cold, the fluid level should be no more than 1/8 inch (3 mm) showing on the dipstick.

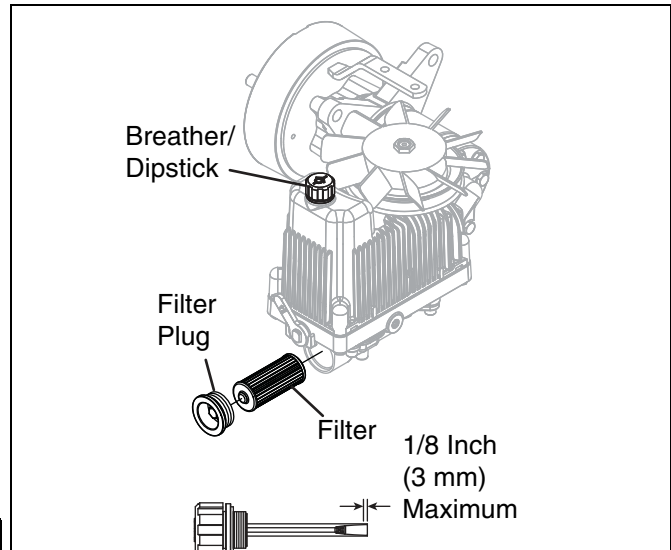

**CAUTION**

When you remove the air from the drive axles, the rear wheels will turn. To prevent injury, use caution to prevent contact with the wheels.

- f Start the engine and disengage the parking brake.
- g Slowly move the steering control levers from the Neutral Position, to the full forward position, to the full reverse position and return the handles to the Neutral position. Repeat 5 to 6 times.
- h Stop the engine and add fluid to the drive axle as needed. When cold, the fluid level should be no more than 1/8 inch (3 mm) showing on the dipstick. Check for fluid leaks around the filter plug.
- i If needed, repeat steps f~h until the drive axles operate at normal noise levels and the tires move smoothly in the forward and reverse directions.

## 8 MAINTENANCE

### 8.12 FOLDING ROPS

A folding Roll Over Protective Structure (ROPS) is included with this mower. Inspect the ROPS periodically for loose hardware or damage.

#### CAUTION

Keep the ROPS hardware correctly fastened. Do not do welding operations, drill, change or bend the ROPS. Replace damaged ROPS. Do not try to correct a damaged ROPS.

Every 400 hours, inspect the seat, seat belt, ROPS mounting hardware and ROPS frame for damage. Replace all damaged parts immediately. All replacement parts for the ROPS must be as specified in the Parts Manual.

Check and torque all ROPS hardware every 100 hours.

Only operate the mower with the ROPS in the folded position on flat and level surfaces. Do not operate the mower with the ROPS in the folded position on the slopes, near sharp edges or near water. **There is no roll over protection with the ROPS in the folded position.**

Folding the ROPS.

- a Remove the hair pin and ROPS pin from both sides of the ROPS.
- b Fold the ROPS toward the back of the mower.
- c Assemble the ROPS pin and hair pin to lock the ROPS in the folded position. **Never** wear the seat belt with the ROPS in the folded position.

#### WARNING

To prevent injury when you fold the ROPS, use caution to prevent your fingers crushed between moving and rigid parts of the ROPS.

Always wear the seat belt with the ROPS frame in the vertical and locked position.

**Never wear the seat belt with the ROPS in the folded position.**

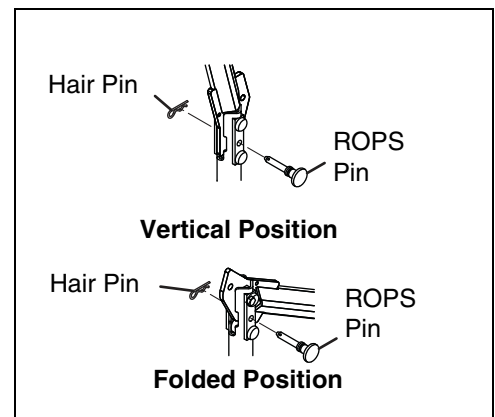

**8.13 AIR COOLING SYSTEM**

The engine on the mower is an air-cooled engine. Dirt and other objects can decrease the air flow and cause the engine to overheat, cause bad performance and decreased engine life.

<b>NOTICE</b>
Do not use water to clean the engine. Water can cause contamination in the fuel system. Use a brush or clean cloth to clean the engine.

- Use a brush or a dry cloth to clean the air intake area.
- Keep throttle linkage, springs and controls clean.
- Use compressed air to remove debris from the engine oil cooler fins.
- Refer to the Engine manual for additional information.

**8.14 INSPECTING BLADES**

Every 50 hours of operation or when the cutting unit is removed from the mower, carefully inspect the blades to make sure the blades are in good condition. Replace any blade that has bends, grooves or cracks.

<b>CAUTION</b>
Be careful when you check blades to prevent pinching hands and fingers between ends of the blades.

<b>WARNING</b>
Never try to correct or repair a damaged blade. Always replaced a damaged blade.
The bends, grooves or cracks can cause a piece of the blade to become loose and be discharged from the mower. The broken blade pieces can cause injury to persons or property damage.

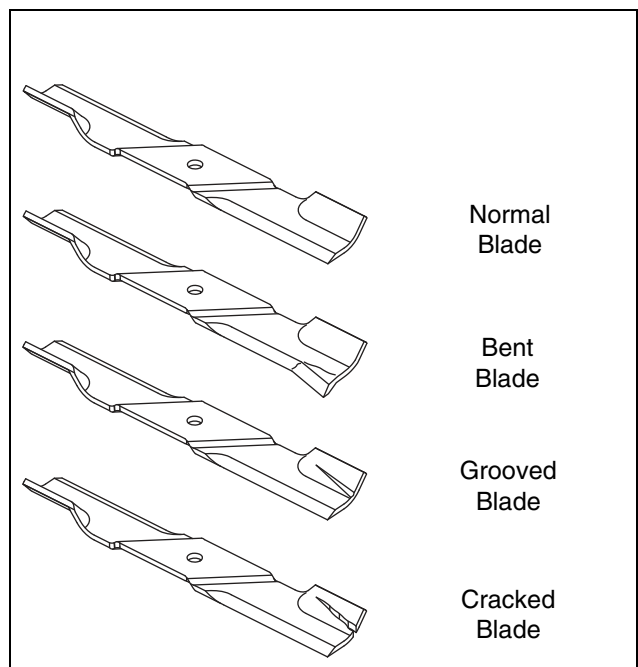

A bent blade can have a small crack that can increase and cause a piece of the blade to break. The bent blades can cause vibration and other stress on the mower.

The dust or sand particles can wear a dangerous groove in the blade between the air vanes and the flat part of the blade. The groove can quickly increase in size and allow a piece of the blade to break.

## 8 MAINTENANCE

### 8.15 SHARPENING BLADES

Put a wooden block between the blade and cutting unit housing to prevent the blade to rotate.



#### WARNING

The cutting unit blades can have sharp edges. To prevent injury, use caution when you service or hold the blade.

When you remove more than one half inch of material, the blade tip can break and be discharged from the mower. The broken blade pieces can cause injury to persons or property damage.

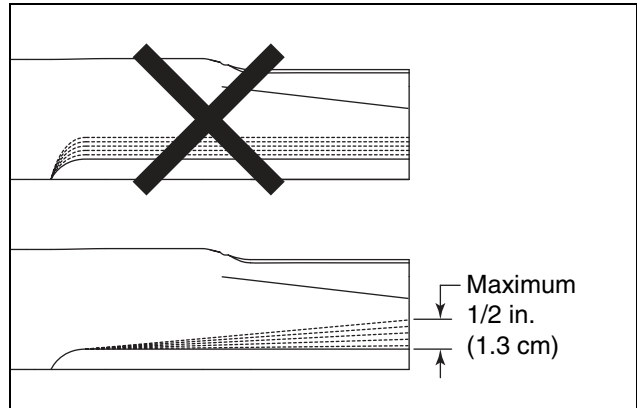

When you prepare or sharpen the blade, do not follow the original grind pattern. Grind new cutting edges at an angle. If the maximum of one half inch (1.3 cm) blade loss has occurred, do not sharpen more, replace the blade.

To prevent a blade that is not balanced, make sure an equal amount of material is removed from both ends of the blades. A blade that is not balanced will cause vibration and can damage the mower. Use a blade balancer to check the blade after you sharpen.

Torque center blade bolt to 125-135 ft.Lb. (169 to 183 Nm).

### 8.16 ELECTRICAL SYSTEM



#### CAUTION

Always turn the ignition switch to the off position and remove the negative (BLACK) battery cable before you inspect or service the electrical system.

General precautions to decrease electrical problems are -

- Make sure that all the connections are clean and correctly fastened.
- Check the Interlock system, fuses and circuit breakers at normal intervals. If the Interlock system does not operate correctly and you can not correct the problem, contact an authorized Dixie Chopper Dealer.
- Keep the wiring harness away from hot surfaces and moving parts.
- Never disconnect or reconnect the ECU harness connector or any individual components with the ignition switch in the ON position. Disconnecting connectors with the power on can cause damaging voltage spikes through the ECU.
- Check the battery and the alternator.
- Do not wash or pressure spray around electrical connections and components.



**8.17 BELTS**

Replace the belts if they show signs of cuts, tears, burns caused by slipping or excessive wear.

To remove the belts, reduce belt tension by pulling the idler pulley away from the belt. Note the belt routing and remove the belts from the pulleys. The new belt must use the same belt routing.

**48 Inch (122 cm) Deck  
Belt Routing**

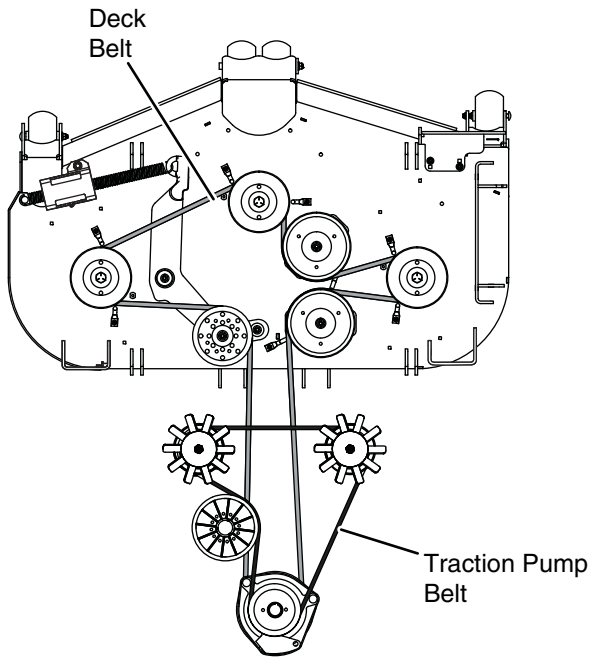

**54 Inch (137 cm) Deck  
Belt Routing**

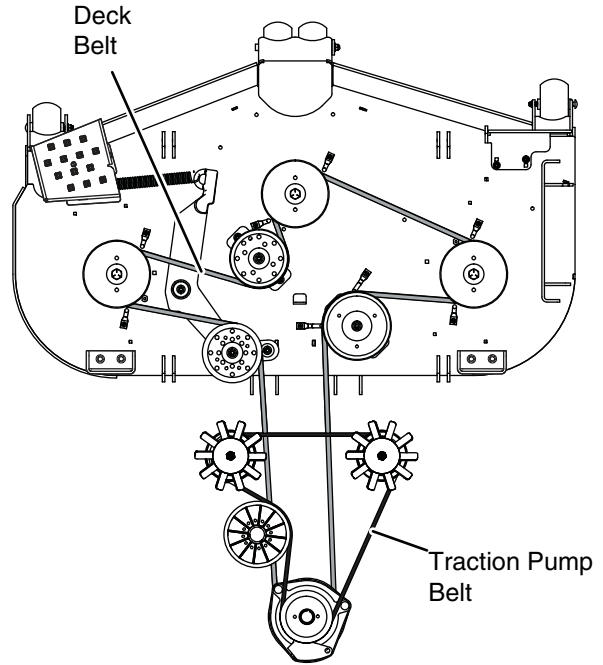

**60 Inch (152 cm) Deck  
Belt Routing**

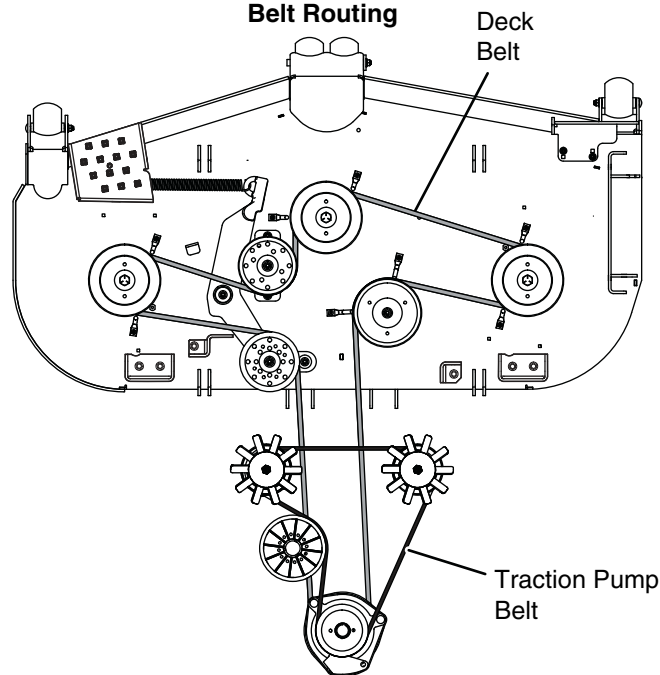

## 8 MAINTENANCE

---

### 8.18 CARE AND CLEANING

---

Clean the mower and cutting units after each use. To prevent damage to the engine, do not wash the mower with the engine in operation. When possible, clean the mower with compressed air.

#### NOTICE

Do not wash any part of the mower that is hot. Do not use the high-pressure spray or steam. Use cold water and automotive cleaners.

Use compressed air to clean the engine and the engine oil cooler fins. Do not pressure wash the engine.

Use clean water to wash your equipment.

#### NOTICE

To use salt water or drain water is known to cause rust and corrosion of metal parts and can cause damage or failure. This damage is not included by the factory warranty.

Do not spray water at the control panel, ignition switch or other electrical components.

Clean all plastic or rubber parts with a weak soap solution or use commercially available rubber cleaners.

To keep the original high polish of the fiberglass parts, wax with a good grade of one-step cleaner wax.

Repair damaged metal surfaces and use Dixie Chopper touch-up paint. Apply wax to the equipment for maximum paint protection.

#### CAUTION

To prevent fire, clean grass clippings and dirt from the cutting unit, drives, engine and exhaust components.

#### WARNING

**Never** use your hands to clean cutting units. Use a brush to remove grass clippings from the blades. The blades are sharp and can cause injuries.

## 8.19 MOWER STORAGE

### General

- Clean the mower and lubricate. Repair and paint damaged or open metal.
- Inspect the mower, tighten all hardware, replace worn or damaged components.
- Clean the tires and keep the mower so that the load is not on the tires. If the mower is not on the jack stands, check tires at normal intervals and add air when needed.
- Keep the mower and all accessories clean, dry and protected from the elements. Never keep the mower near an open flame or spark which can cause ignition of the fuel or fuel vapors.

### Battery

- Remove, clean and keep the battery in the upright position on a surface that is not metal in a cool dry location. To prevent increased battery discharge, do not keep the battery on a metal surface.
- Check and charge the battery every 60 to 90 days.
- Keep the battery in a cool dry location. To decrease the self discharge rate, the temperature must not be more than 80° F (27° C) or less than 20° F (-7° C).

### Engine

- Change the engine oil and filter.
- Clean the outside surface of the engine. Paint bare metal or apply a thin layer of rust preventative oil.
- Add a fuel stabilizer to prevent the fuel to become stale. See your fuel supplier for instructions. Start the engine. Operate the engine for two minutes to circulate the stabilizer throughout the fuel system.

### Cutting Units

- Completely clean the cutting units. Repair and paint any damaged or bare metal surfaces.
- Lubricate all grease fittings and friction points.
- Apply a thin layer of rust preventative oil to the sharpened edges of the blades.



## CAUTION

The cutting unit blades can have sharp edges. To prevent injury, use caution when you service or hold the blade.

### After Storage

- Check and install the battery. If necessary, charge the battery.
- Check or service the fuel filter and air cleaner
- Check the level of engine oil and drive axle fluid.
- Fill the fuel tank with fuel.
- Make sure the tires are correctly inflated.
- Remove all oil from the blades.
- Start the engine at 1/2 throttle. Allow the engine to become warm and lubricated.



## WARNING

**Never** operate the engine without enough ventilation or in an enclosed area. The carbon monoxide in the exhaust fumes can increase to dangerous levels.

## 9 ADJUSTMENTS

### 9.1 GENERAL PRECAUTIONS

#### **WARNING**

Before you clean, adjust or repair this equipment, push PTO switch to the OFF position, lower the cutting unit to the ground, turn on the parking brake switch, stop the engine and remove the key.

Make sure the mower is parked on a solid and level surface. Never work on a mower that is lifted only by the jack. Always use the jack stands.

A qualified technician must always do adjustments and maintenance. If the correct adjustments can not be made, contact your Dixie Chopper Dealer.

Inspect the equipment according to the maintenance schedule and keep complete records.

- a Keep the equipment clean.
- b Keep all moving parts correctly adjusted and lubricated.
- c Replace worn or damaged parts before you operate the mower.
- d Keep all fluids at the correct level.
- e Keep the shields in position and all hardware tight.
- f Keep the tires correctly inflated.

When you make the adjustments or repairs, do not wear jewelry or loose fitting clothing.

Refer to the illustrations in the Parts Manual for the removal and assembly of parts.

When you discard hazardous materials (batteries, lubricants, fuel, anti-freeze), follow your local, state or federal-recommended procedures.

### 9.2 FORWARD SPEED LIMIT SCREWS

The cutting quality is improved at speeds lower than the full transport speed of the mower. The local turf condition may require a different speed.

To adjust the forward speed, adjust the speed limit screws at the front of the seat support. Turn the screws to the right-side to decrease the forward speed. Turn the screws toward the left side to increase the forward speed.

Make certain the speed limit screws on both sides of the mower are set to the same adjustment.

Test drive the mower. If the mower steers to the right or left when both steering control levers are pushed all the way forward, tracking adjustment may be required.

- If the mower steers to the right, adjust the speed limit screw on the left side of the mower to decrease the left drive axle speed.
- If the mower steers to the left, adjust the speed limit screw on the right side of the mower to decrease the right drive axle speed.

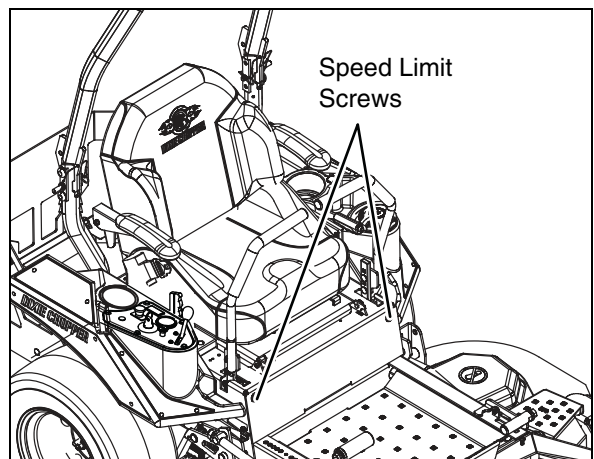





9.3 TORQUE SPECIFICATION





**NOTICE**

The torque values included in these charts are approximate and are for reference only. Use these torque values at your risk. Dixie Chopper is not responsible for any loss, claim or damage caused by these charts. **Always use caution with torque values.**

Dixie Chopper uses Grade 5 (Inch) and Grade 8.8 (Metric) Plated bolts, unless a note is given. Always check the marks on the head of the bolts for the bolt grade. For tightening plated bolts, use the value given for lubricated.

SIZE	UNITS									SIZE	UNITS				
		GRADE 5		GRADE 8		GRADE 5		GRADE 8							
		Lubricated	Dry	Lubricated	Dry	Lubri- cated	Dry	Lubri- cated	Dry						
#6-32	in-lb (Nm)	–	20 (2.3)	–	–	7/16-14	ft-lb (Nm)	37 (50.1)	50 (67.8)	53 (71.8)	70 (94.9)				
#8-32	in-lb (Nm)	–	24 (2.7)	–	30 (3.4)	7/16-20	ft-lb (Nm)	42 (56.9)	55 (74.6)	59 (80.0)	78 (105)				
#10-24	in-lb (Nm)	–	35 (4.0)	–	45 (5.1)	1/2-13	ft-lb (Nm)	57 (77.2)	75 (101)	80 (108)	107 (145)				
#10-32	in-lb (Nm)	–	40 (4.5)	–	50 (5.7)	1/2-20	ft-lb (Nm)	64 (86.7)	85 (115)	90 (122)	120 (162)				
#12-24	in-lb (Nm)	–	50 (5.7)	–	65 (7.3)	9/16-12	ft-lb (Nm)	82 (111)	109 (148)	115 (156)	154 (209)				
1/4-20	in-lb (Nm)	75 (8.4)	100 (11.3)	107 (12.1)	143 (16.1)	9/16-18	ft-lb (Nm)	92 (124)	122 (165)	129 (174)	172 (233)				
1/4-28	in-lb (Nm)	85 (9.6)	115 (13.0)	120 (13.5)	163 (18.4)	5/8-11	ft-lb (Nm)	113 (153)	151 (204)	159 (215)	211 (286)				
5/16-18	in-lb (Nm)	157 (17.7)	210 (23.7)	220 (24.8)	305 (34.4)	5/8-18	ft-lb (Nm)	128 (173)	170 (230)	180 (244)	240 (325)				
5/16-24	in-lb (Nm)	173 (19.5)	230 (26.0)	245 (27.6)	325 (36.7)	3/4-10	ft-lb (Nm)	200 (271)	266 (360)	282 (382)	376 (509)				
3/8-16	ft-lb (Nm)	23 (31.1)	31 (42.0)	32 (43.3)	44 (59.6)	3/4-16	ft-lb (Nm)	223 (302)	298 404	315 (427)	420 (569)				
3/8-24	ft-lb (Nm)	26 (35.2)	35 (47.4)	37 (50.1)	50 (67.8)	7/8-14	ft-lb (Nm)	355 (481)	473 (641)	500 (678)	668 (905)				

SIZE	UNITS									Non Critical Fasteners into Aluminum
		4.6		8.8		10.9		12.9		
		Lubricated	Dry	Lubricated	Dry	Lubricated	Dry	Lubricated	Dry	
M4	Nm (in-lb)	–	–	–	–	–	–	3.83 (34)	5.11 (45)	2.0 (18)
M5	Nm (in-lb)	1.80 (16)	2.40 (21)	4.63 (41)	6.18 (54)	6.63 (59)	8.84 (78)	7.75 (68)	10.3 (910)	4.0 (35)
M6	Nm (in-lb)	3.05 (27)	4.07 (36)	7.87 (69)	10.5 (93)	11.3 (102)	15.0 (133)	13.2 (117)	17.6 (156)	6.8 (60)
M8	Nm (in-lb)	7.41 (65)	9.98 (88)	19.1 (69)	25.5 (226)	27.3 (241)	36.5 (323)	32.0 (283)	42.6 (377)	17.0 (150)
M10	Nm (ft-lb)	14.7 (11)	19.6 (14)	37.8 (29)	50.5 (37)	54.1 (40)	72.2 (53)	63.3 (46)	84.4 (62)	33.9 (25)
M12	Nm (ft-lb)	25.6 (19)	34.1 (25)	66.0 (48)	88.0 (65)	94.5 (70)	125 (92)	110 (81)	147 (108)	61.0 (45)
M14	Nm (ft-lb)	40.8 (30)	54.3 (40)	105 (77)	140 (103)	150 (110)	200 (147)	175 (129)	234 (172)	94.9 (70)

# 10 PROBLEM SOLVING

---

## 10.1 GENERAL

---

The problem solution chart lists basic problems that can occur during start and operation of the mower. For complete information about the drive axle and electrical systems, contact your Dixie Chopper Dealer.

Symptoms	Possible Causes	Action
<b>Engine will not start.</b>	<ol style="list-style-type: none"><li>1. Parking brake disengaged or power take-off switch ON.</li><li>2. Battery low on charge or defective.</li><li>3. Fuel tank empty or dirty.</li><li>4. Fuse blown.</li><li>5. Relay(s) defective.</li></ol>	<ol style="list-style-type: none"><li>1. Check Interlock System and start-up procedure.</li><li>2. Inspect condition of battery and battery connections.</li><li>3. Fill with fresh fuel. Change fuel filter.</li><li>4. Replace fuse.</li><li>5. Test and replace relay.</li></ol>
<b>Engine hard to start or runs poorly.</b>	<ol style="list-style-type: none"><li>1. Fuel level low, fuel or fuel filter dirty.</li><li>2. Air cleaner dirty.</li><li>3. Engine problem.</li></ol>	<ol style="list-style-type: none"><li>1. Fill with fresh fuel. Change fuel filter.</li><li>2. Inspect and replace air filter.</li><li>3. Consult engine manual.</li></ol>
<b>Engine stops.</b>	<ol style="list-style-type: none"><li>1. Fuel tank empty.</li><li>2. Interlocks not set before leaving operator's position.</li></ol>	<ol style="list-style-type: none"><li>1. Fill with fresh fuel and bleed fuel lines.</li><li>2. Engage parking brake and set power take-off switch to OFF.</li></ol>
<b>Engine overheating.</b>	<ol style="list-style-type: none"><li>1. Air intake restricted.</li></ol>	<ol style="list-style-type: none"><li>1. Clean engine cooling air intake and fins.</li></ol>
<b>Battery not holding charge.</b>	<ol style="list-style-type: none"><li>1. Loose or corroded battery terminals.</li><li>2. Low electrolyte.</li><li>3. Charging system defective.</li></ol>	<ol style="list-style-type: none"><li>1. Inspect and clean terminals.</li><li>2. Refill to correct level.</li><li>3. See engine manual.</li></ol>
<b>Cutting unit does not cut evenly.</b>	<ol style="list-style-type: none"><li>1. Deck not level.</li><li>2. Engine speed too low.</li><li>3. Mow speed not adjusted for turf conditions.</li></ol>	<ol style="list-style-type: none"><li>1. Check that decks are level. Check and adjust cutting height.</li><li>2. Check engine speed with throttle in its fast position.</li><li>3. Adjust mow speed for best cut.</li></ol>

**10.2 BLACKHAWK HP MODEL FAULT CODES**

When a fault is detected by the display panel, it is displayed on the LCD display as a numeric code. Below is a chart of the error codes and potential sources.

<b>Fault Code</b>	<b>Description</b>
10	Check battery condition and connections, check starter solenoid wiring for shorts
11	Check battery condition and connections, check PTO and PTO wiring for shorts.
12	Check battery condition and connections, check fuel solenoid and fuel solenoid wiring for shorts.
13	Check headlight wiring for shorts.
14	Check battery condition and connections, check deck motor and wiring for shorts.
15	Check battery condition and connections.
16	Check battery condition and connections, check starter and fuel solenoid connections for shorts
17	Check battery condition and connections, check PTO and PTO wiring for shorts.
18	Check battery connections, check fuel solenoid and wiring for shorts.
19	Check battery connections, check headlight wiring for shorts.
20	Check battery condition and connections, check deck motor and wiring for shorts.
21	Check battery condition and connections, check all wiring for shorts.
22	Excessive system current.
23	Check battery condition and connections, check starter solenoid wiring for shorts.
24	Check battery condition and connections, check PTO and PTO wiring for shorts.
25	Check PTO current.
26	Excessive system current.
27	Excessive system current, check headlight.
28	Excessive system current, check for binding deck lift or problem with deck lift motor.
29	Excessive system current.
30	Console internal fault.
39	Console internal fault, some or all power functions disabled.
40	Console internal fault.



**DIXIE CHOPPER**  
**6302 E. County Road 100 N.**  
**Coatesville, Indiana 46121**  
**[www.dixiechopper.com](http://www.dixiechopper.com)**

Specifications and instructions subject to change without notice.

Dixie Chopper is a registered trademark of Jacobsen Professional Lawn Care Inc.  
any and all use and/or reproductions are strictly prohibited.

Printed In USA